

DRAWING NUMBER	TITLE
9-1	STORM DRAIN PIPE BEDDING AND INITIAL BACKFILL (10/09)
9-7A	STANDARD PRECAST CONCRETE DRAINAGE MANHOLE (8/10)
9-8A	TYPE A SADDLE MANHOLE (11/98)
9-9	GREY CAST IRON STANDARD 24" MANHOLE FRAME & COVER (10/09)
9-10	GREY CAST IRON STANDARD 36" MANHOLE FRAME & COVER (08/10)
9-11	GRATE TYPE MANHOLE COVER (08/10)
9-13B	DROP INLET TYPE B (10/09)
9-13C	DROP INLET TYPE C (01/09)
9-14	WELDED STEEL GRATE FRAME (04/07)
9-15	WELDED STEEL GRATE (04/07)
9-16	CENTER SUPPORT ASSEMBLY FOR MULTIPLE GRATES(04/07)
9-17	CATCH BASIN FACE PLATE ASSEMBLY AND PROTECTION BAR (04/07)
9-18	DROP INLET TYPE F (10/09)
9-19	DROP INLET TYPE G (10/09)
9-20	CORRUGATED METAL PIPE DRAINAGE INLET TYPE I (10/09)
9-21	PRECAST DROP INLET TYPE J (10/15)
9-22	CORRUGATED PIPE FITTINGS (11/98)
9-23	PIPE CONNECTIONS (01/03)
9-24	LINED CHANNEL SECTION (10/09)
9-26G	TRASH RACK 24"-36" PIPE (10/09)
9-26H	PIPE HEADWALL, ENDWALL WINGWALL STRUCTURE (10/09)
9-27	EROSION CONTROL DITCH DISCHARGE (10/09)
9-28	BARBED WIRE AND WIRE MESH FENCES (11/98)
9-29	CHAIN LINK FENCE (12/99)
9-30	UTILITY STREAM CROSSING(10/09)
9-31	FLEXIBLE CONNECTOR PIPE TO MANHOLE (10/09)
9-32	CONSTRUCTION SITE SIGN (02/07)
9-33	UTILITY CROSSING (04/97)
9-34	CAST IRON 24" MANHOLE FRAME & COVER FOR TYPE G AND 300-1 INLET (4/07)
9-35	WATER STOP (10/09)
9-36	24" MANHOLE FRAME & COVER FOR TYPE J INLET (10/15)
300-1	CURB OPENING CATCH BASIN (12/02)
301-1	CURB OPENING CATCH BASIN (12/02)
308-0	MONOLITHIC CATCH BASIN CONNECTION (3/07)
309-0	CATCH BASIN REINFORCEMENT (01/06)

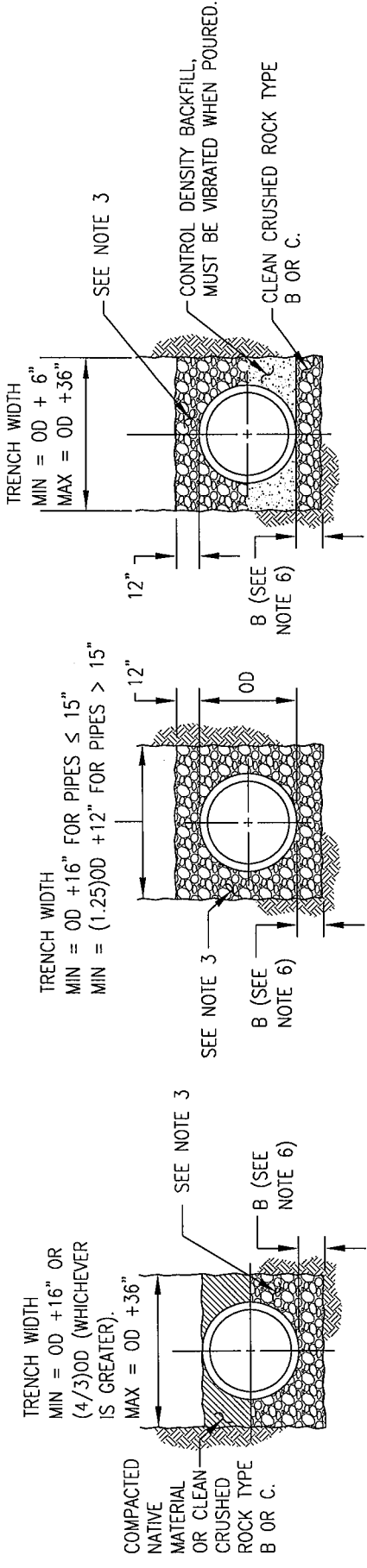

RIGID PIPE
REINFORCED CONCRETE
PIPE C-76

FLEXIBLE PIPE
PVC, CORRUGATED
AND RIBBED METAL

**CONTROL DENSITY
BACKFILL FOR FLEXIBLE PIPE**
SEE NOTE 4

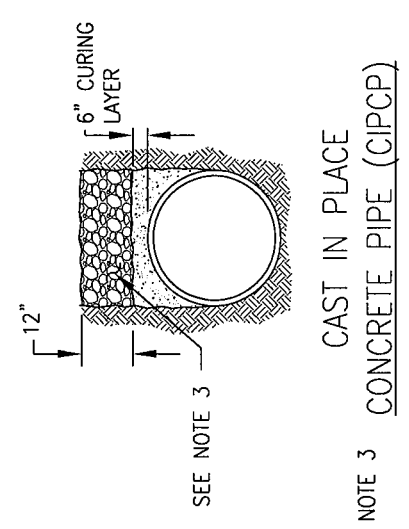

**CAST IN PLACE
CONCRETE PIPE (CICPP)**

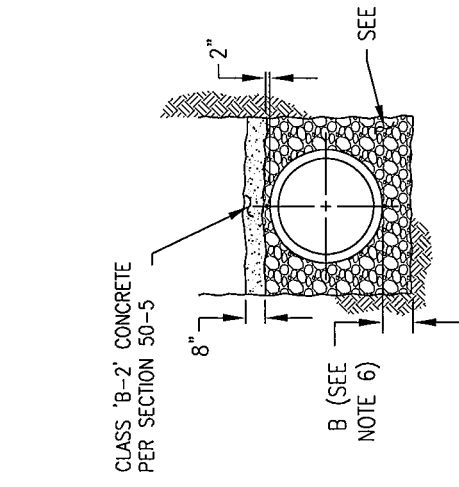

COVER LESS THAN STANDARD
SEE NOTE 5

- GENERAL NOTES:**
1. AREA ABOVE BEDDING AND INITIAL BACKFILL PER DRAWING 4-31.
 2. SEE SECTION 19 "TRENCH EXCAVATION BEDDING AND BACKFILL".
 3. BACKFILL WITH CLEAN CRUSHED ROCK TYPE B OR C.
 4. IF MINIMUM TRENCH WIDTH CANNOT BE ACHIEVED, CONTROL DENSITY BACKFILL, PER SECTION 50-15 SHALL BE USED (UP TO SPRING LINE) IN LIEU OF CLEAN CRUSHED ROCK AT NO EXTRA COST (WITH APPROVAL OF THE DIRECTOR).
 5. COVER LESS THAN STANDARD WILL ONLY BE ALLOWED IF THE MINIMUM COVER OVER THE PIPE BELL IS LESS THAN TABLE 38-1 AND WITH THE APPROVAL OF THE DIRECTOR.
 6. B=4" FOR PIPES 12"-54" ID AND B=6" FOR PIPES >54" ID OR MINIMUM DEPTH OF BEDDING MATERIAL SHALL BE 1-1/2" BELOW THE PIPE BELL, WHICHEVER IS GREATER.
 7. THE TRENCH WIDTH ABOVE THE PIPE MAY BE INCREASED FOR CONSTRUCTION PURPOSES.
 8. THE MINIMUM TRENCH WIDTH CALCULATIONS ARE BASED ON THE PIPE PLACED IN THE CENTER OF A TRENCH. IF A PIPE CAN NOT BE PLACED IN THE CENTER OF A TRENCH, THE TRENCH SHALL BE WIDENED SO THAT ON BOTH SIDES OF THE PIPE, THE DISTANCE FROM THE TRENCH WALL TO THE OUTSIDE OF THE PIPE IS EQUAL TO (TRENCH WIDTH - PIPE OD)/2.

Michael L. Peterson
DIRECTOR, DEPARTMENT OF WATER RESOURCES
JANUARY 2014

IN PAVED AREAS SET FLUSH WITH PAVEMENT. IN UNPAVED AREAS WITH GRATE TYPE COVERS SET 1" BELOW ADJACENT GRADE.

6" CONCRETE COLLAR W/2-#4 HOOPS IN UNPAVED AREAS

PROVIDE FRAME AND COVER PER DRAWING 9-9A. USE OF GRATE TYPE COVER IN UNPAVED AREAS PER DRAWING 9-9B OR 9-11 BY DIRECTOR APPROVAL.

4" CONCRETE COLLAR IN PAVED AREAS

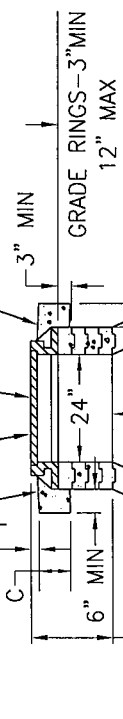

CONE TOP

IN PAVED AREAS SET FLUSH WITH PAVEMENT. IN UNPAVED AREAS WITH GRATE TYPE COVERS SET 1" BELOW ADJACENT GRADE.

6" CONCRETE COLLAR W/2-#4 HOOPS IN UNPAVED AREAS

PROVIDE FRAME AND COVER PER DRAWING 9-9A. USE OF GRATE TYPE COVER IN UNPAVED AREAS PER DRAWING 9-9B OR 9-11 BY DIRECTOR APPROVAL.

4" CONCRETE COLLAR IN PAVED AREAS

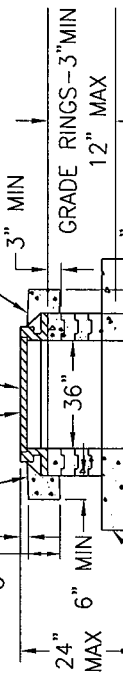

FLAT TOP

C = 6.5" WITH ONE GRADE RING AND 8" WITH TWO OR MORE GRADE RINGS.

PRECAST REINFORCED MANHOLE SECTIONS (REBAR NOT SHOWN)

RESILIENT CONNECTOR SEE NOTE 2

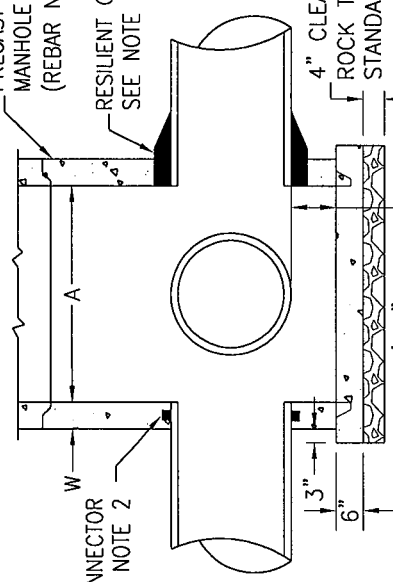

1'-0" SUMP SEE NOTE 3 ROUND OR BOX BASE

PIPE OPENINGS PER PLAN

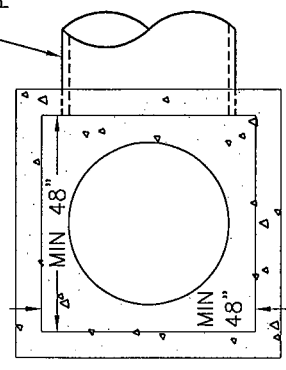

BOX BASE (PLAN VIEW)

TABLE OF MINIMUM DIMENSIONS FOR ROUND MANHOLES

M.H.	A	B	W
48"	48"	18"	5"
60"	60"	30"	6"
72"	72"	**	7"
84"	84"	54"	8"
96"	96"	---	9"

** - TRANSITION SLAB REDUCES THE INSIDE DIAMETER FROM 72" TO 60"

SACRAMENTO COUNTY
MUNICIPAL SERVICES AGENCY

STANDARD PRECAST CONCRETE DRAINAGE MANHOLE

DRAWN BY: STAFF
SCALE: NONE
REVISION DATE: 08/10

9-7A
SHEET 1 OF 2

Michael L. Peterson

DIRECTOR, DEPARTMENT OF WATER RESOURCES
JANUARY, 2014

NOTES:

1. ALL MANHOLES SHALL MEET H-20 LOAD SPECIFICATIONS.
2. PRECAST MANHOLES SHALL USE FLEXIBLE COMPRESSION GASKET OR BOOT CONNECTOR CONFORMING TO ASTM C-923. (CONNECTION SHALL BE WATER AND SOIL TIGHT). FOR PIPES GREATER THAN 30" I.D., BASE MAY BE CAST-IN-PLACE WITH A WATER STOP CONFORMING TO ASTM C-923.
3. SUMP SHALL BE 1'-0" DEEP, MEASURED FROM INVERT OF OUTFALL PIPE. SUMP NOT REQUIRED IF OUTFALL PIPE IS 24" I.D. OR LARGER. SUMPS SHALL NOT BE ALLOWED OUT OF THE COUNTY RIGHT OF WAY.
4. RISER SECTIONS, CONES, AND ADJUSTING RINGS SHALL CONFORM TO ASTM C-478.
5. ALL JOINTS SHALL BE MADE WITH PREFORMED PLASTIC JOINT SEALING COMPOUND OR PRE-LUBRICATED GASKET. FOLLOWING INSTALLATION, GROUT ALL INTERIOR AND EXTERIOR JOINTS.
6. CONCENTRIC COMPONENTS SHALL BE USED UNLESS OTHERWISE SPECIFIED ON THE PLANS.
7. PRECAST MANHOLES SHALL BE SIZED TO PROVIDE THE FOLLOWING: THE ANNULAR SPACE ON THE INSIDE OF THE MANHOLE BARREL BETWEEN CORED PIPE CONNECTION HOLES SHALL BE A MINIMUM OF 12-INCHES OR HALF THE DIAMETER OF THE SMALLER CORED HOLE (WHICHEVER IS GREATER). IF THE CONNECTION HOLE IS CAST MONOLITHICALLY WITH THE MANHOLE BARREL THE MEASUREMENT SHALL BE TAKEN FROM THE FINISHED CONCRETE CONNECTION SURFACE.
8. SEE SECTION 39, "MANHOLES".
9. CONSTRUCT WITH FLAT SLAB TOP WHEN HEIGHT IS TOO SHALLOW TO CONSTRUCT WITH CONES.
10. FOR THE SLAB REDUCER OF THE BOX MANHOLE (BOX TO ROUND DIAMETER), THE DIAMETER OF THE ROUND REDUCER SHALL NOT BE MORE THAN 12" SMALLER THAN THE INSIDE BOX WIDTH.
11. FLAT SLAB TOP MANHOLES SHALL HAVE A 36" MANHOLE FRAME AND COVER PER DRAWING 9-10.



DIRECTOR, DEPARTMENT OF WATER RESOURCES
JANUARY 2014

SACRAMENTO COUNTY
MUNICIPAL SERVICES AGENCY

**STANDARD PRECAST CONCRETE
DRAINAGE MANHOLE**

DRAWN BY: STAFF
SCALE: NONE
REVISION DATE: 08/10

9-7A
SHEET 2 OF 2

CONCRETE COLLAR PER SHEET
1 OF STD. DWG. 9-7A.

STANDARD 24" FRAME AND COVER. SEE
NOTES ON SHEET 1 OF STD. DWG. 9-7A.

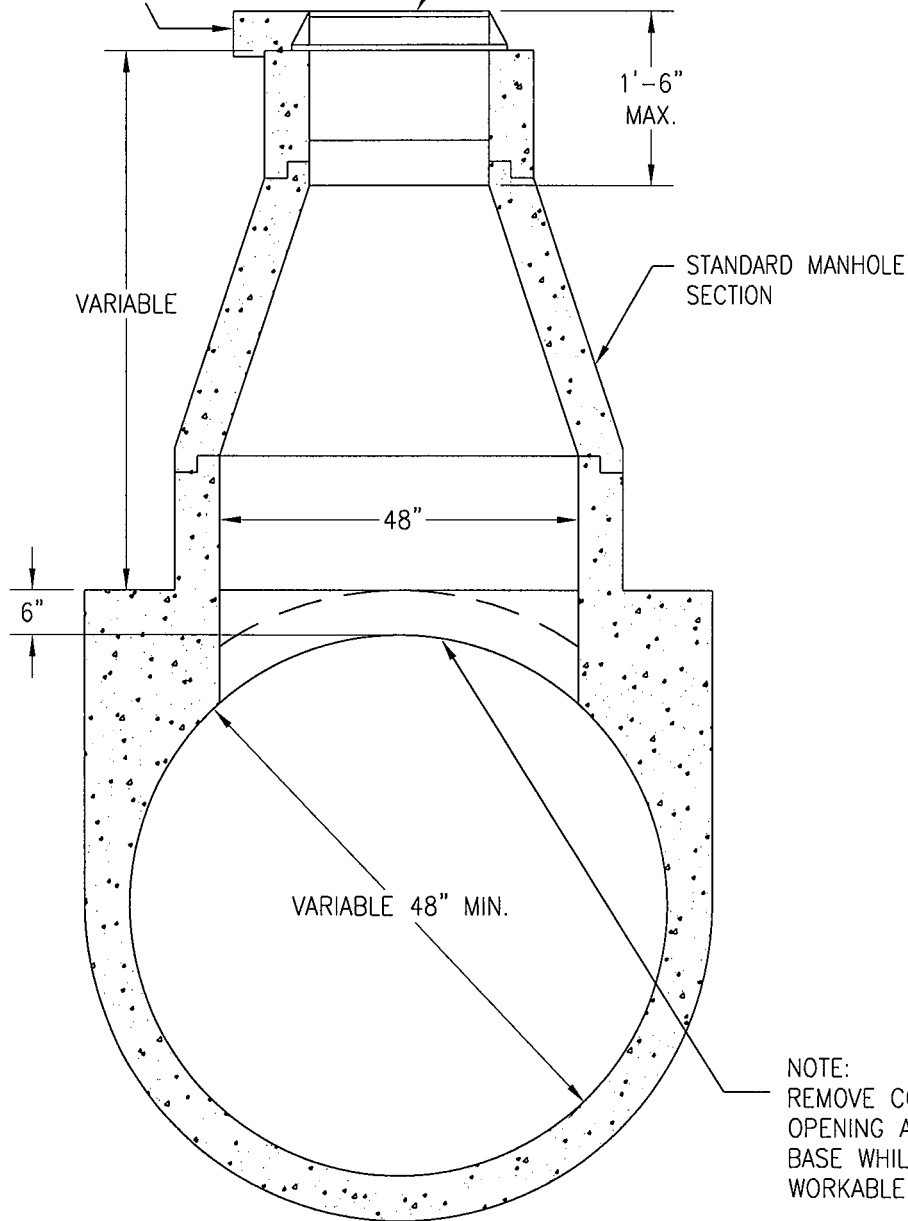

NOTE:
REMOVE CONCRETE IN MANHOLE
OPENING AND CONSTRUCT RISER
BASE WHILE CONCRETE IS STILL
WORKABLE.

PLACE RISER SECTION AFTER
CONCRETE HAS SET.

SEE SECTION 39, "MANHOLES,"
AND SECTION 36, "CAST-IN-PLACE
CONCRETE PIPE."

TYPE A
CAST-IN-PLACE PIPE ONLY

SACRAMENTO COUNTY
MUNICIPAL SERVICES AGENCY

TYPE A
SADDLE MANHOLE

DRAWN BY: M.FIELDS
SCALE: NONE
REVISION DATE: 11/98

9-8A

DIRECTOR, DEPARTMENT OF WATER RESOURCES
JANUARY 2014

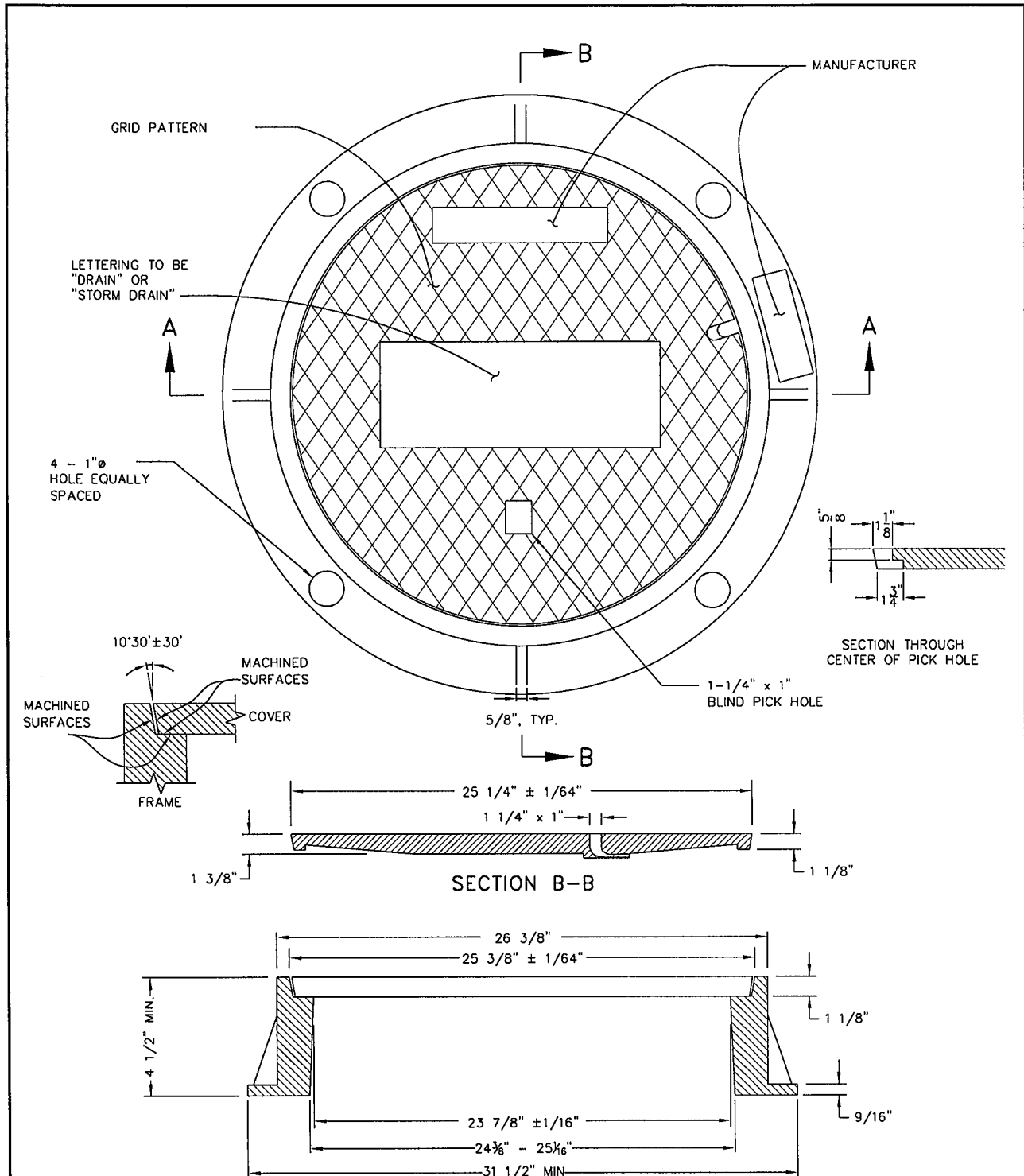

NOTES:

1. ALL CASTINGS TO CONFORM TO ASTM A48, CLASS 35B.
2. FRAME AND COVER TO MEET H-20 LOAD SPECIFICATIONS.
3. EXPOSED SURFACES OF THE CASTING WITH THE PARTS ASSEMBLED AND DISASSEMBLED SHALL BE PAINTED WITH COMMERCIAL QUALITY ASPHALTUM PAINT AFTER TESTING AND ASSEMBLY.
4. LOCKING COVER TYPE FRAME AND COVERS SHALL BE USED IN EASEMENT AREAS UNLESS OTHERWISE APPROVED.
5. SHALL NOT BE USED ON FLAT SLAB TOP MANHOLES.
6. MACHINED HORIZONTAL AND VERTICAL BEARING SURFACES NOT TO EXCEED 1/64" TOLERANCE.

SET WEIGHT	
FRAME	140 LBS
COVER	130 LBS
TOTAL	270 LBS

SACRAMENTO COUNTY
MUNICIPAL SERVICES AGENCY

**GREY CAST IRON
STANDARD 24" MANHOLE
FRAME & COVER**

Michael L. Peters
DIRECTOR, DEPARTMENT OF WATER RESOURCES
JANUARY 2014

DRAWN BY: STAFF
SCALE: NONE
REVISION DATE: 10/09

9-9A

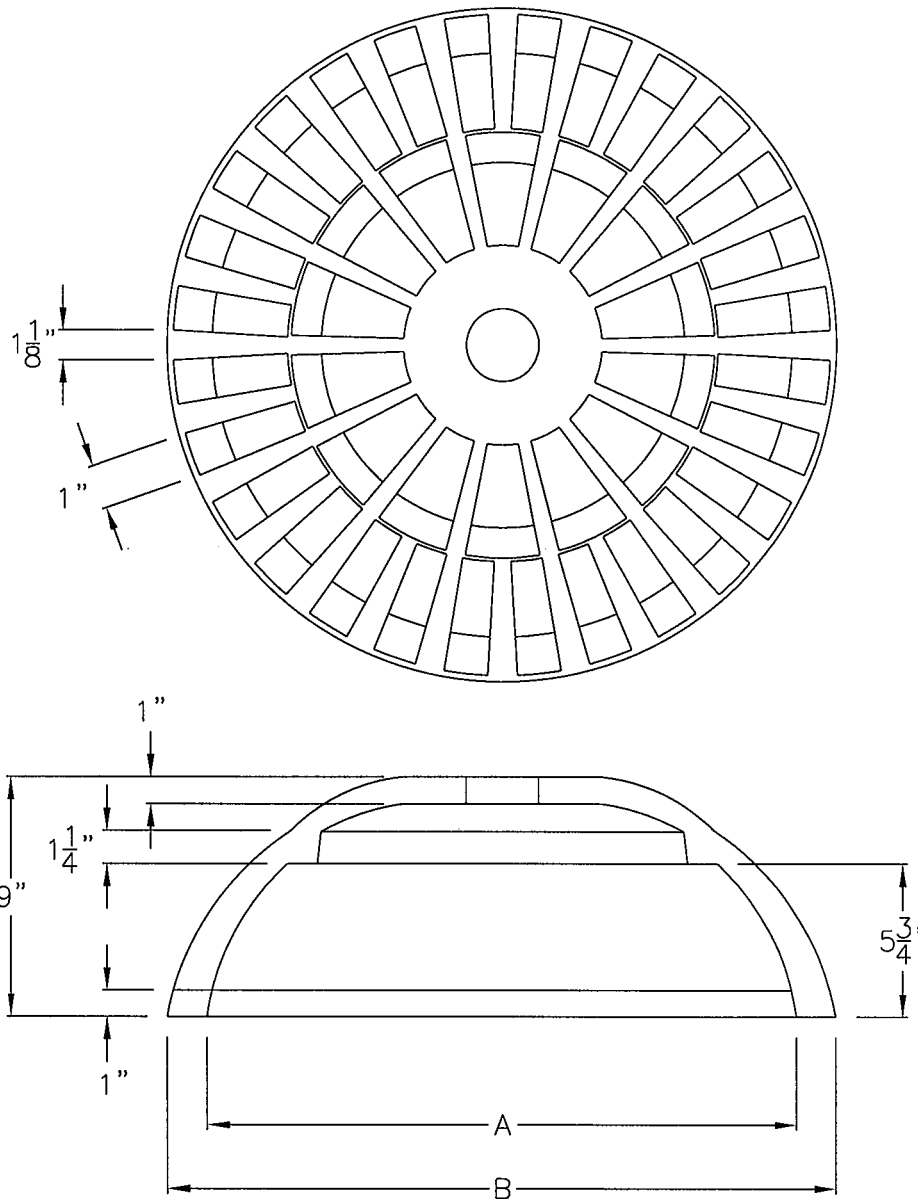

DIMENSION TABLE

LID	A	B
24"	22 ⁵ / ₁₆ "	25 ⁵ / ₁₆ "
36"	35 ¹ / ₄ "	38 ¹ / ₄ "

GENERAL NOTES:

1. CAST IRON TO CONFORM TO ASTM A-48, CLASS 35B.
2. NOT TO BE USED IN COUNTY RIGHT-OF-WAY.
3. EXPOSED SURFACES OF THE CASTING WITH THE PARTS ASSEMBLED AND DISASSEMBLED SHALL BE PAINTED WITH COMMERCIAL QUALITY ASPHALTUM PAINT AFTER TESTING AND ASSEMBLY.
4. LOCKING COVER TYPE FRAME AND COVERS SHALL BE REQUIRED UNLESS OTHERWISE APPROVED.
5. MANHOLE COVER SHALL FIT FRAME SHOWN ON DRAWING 9-9A OR 9-10.
6. THIS COVER MAY ONLY BE USED WITH APPROVAL OF THE DIRECTOR.

Michael L. Peterson

DIRECTOR, DEPARTMENT OF WATER RESOURCES
JANUARY 2014

SACRAMENTO COUNTY
MUNICIPAL SERVICES AGENCY

**BEEHIVE GRATE FOR
STANDARD 24"/36"
MANHOLE COVER**

DRAWN BY: STAFF
SCALE: NONE
REVISION DATE: 08/10

9-9B

OPTIONAL LOCATION FOR
SHOWING COUNTRY OF
ORIGIN ON FRAME

2 LIFT
POCKETS
OPPOSITE SIDES
5/8" RIB @ 60°

4-5/8" HEX-HEAD
STAINLESS STEEL
BOLT @ 90°

COUNTRY OF ORIGIN
UPPER FACE OF COVER
LOWER FACE OF COVER

LETTER D
SEE DETAIL A

8 RIBS @ 45°

SET WEIGHT

FRAME	310 LBS
COVER	290 LBS
TOTAL	600 LBS

PLAN

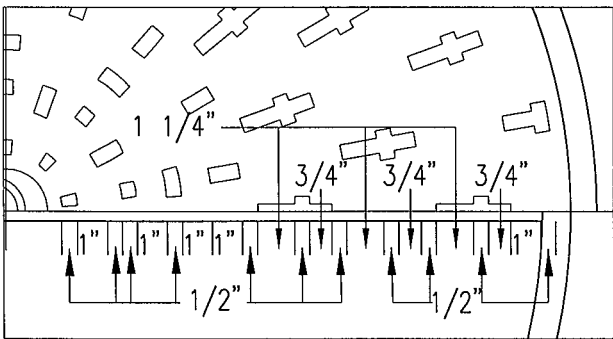

MANUFACTURER

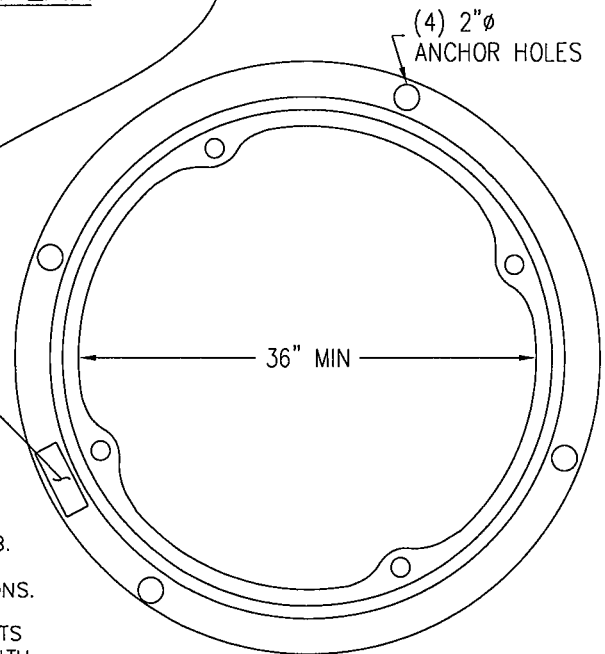

NOTES:

1. MACHINED HORIZONTAL AND VERTICAL BEARING SURFACES NOT TO EXCEED 1/64" TOLERANCE.
2. ALL CASTINGS TO CONFORM TO ASTM A48, CLASS 35B.
3. FRAME AND COVER TO MEET H-20 LOAD SPECIFICATIONS.
4. EXPOSED SURFACES OF THE CASTINGS, WITH THE PARTS ASSEMBLED AND DISASSEMBLED, SHALL BE PAINTED WITH COMMERCIAL QUALITY ASPHALTUM PAINT AFTER TESTING AND ASSEMBLY.
5. LOCKING COVER TYPE FRAME AND COVERS SHALL BE USED WHEN SPECIFIED IN CONTRACT DOCUMENTS.
6. H-20 RATED SLOTTED GRATE OR GRATE TYPE MANHOLE COVER MAY BE SUBSTITUTED FOR COVER WHEN SPECIFIED IN CONTRACT DOCUMENTS OR UPON APPROVAL OF DIRECTOR.
7. SHALL BE USED ON ALL FLAT SLAB TOP MANHOLES.
8. FOR BOLT DOWN COVER - DRILL AND TAP, NO BOSS REQUIRED. USE EXISTING STANDARD PATTERN.

Michael L. Peterson
DIRECTOR, DEPARTMENT OF WATER RESOURCES
JANUARY 2014

SACRAMENTO COUNTY
MUNICIPAL SERVICES AGENCY

**GREY CAST IRON
STANDARD 36" MANHOLE
FRAME & COVER**

DRAWN BY: STAFF
SCALE: NONE
REVISION DATE: 08/10

9-10
SHEET 1 OF 2

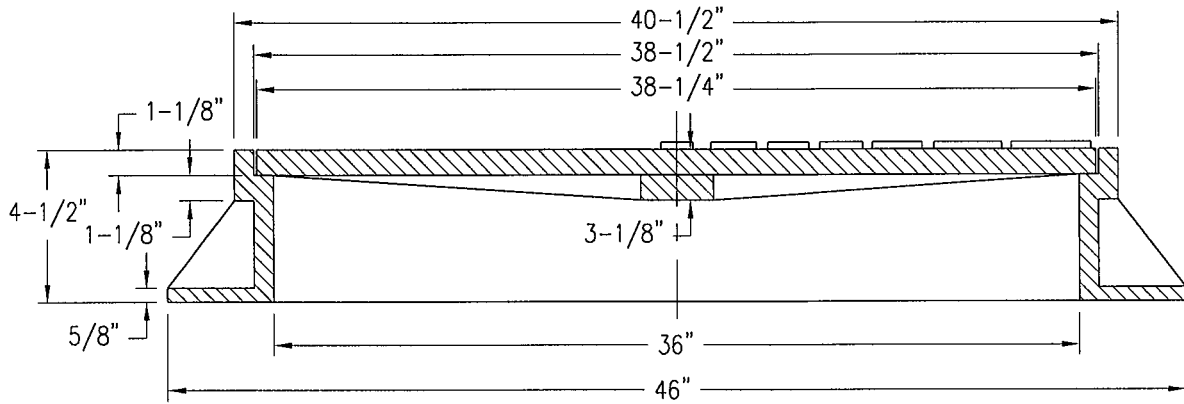

SECTION C-C

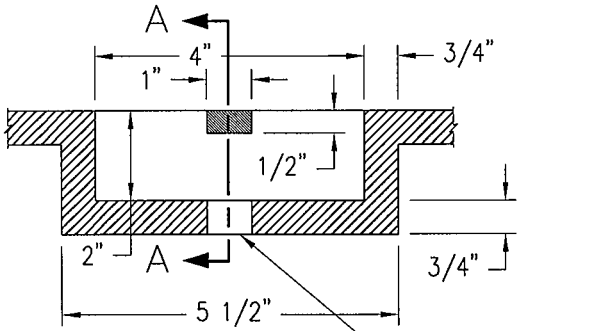

SECTION B-B

NTS.

1" DIA. VENT HOLE

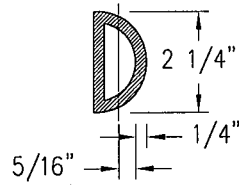

DETAIL A

NTS.

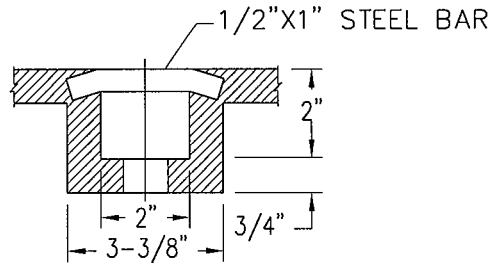

SECTION A-A

NTS.

Michael L. Peters

DIRECTOR, DEPARTMENT OF WATER RESOURCES
JANUARY 2014

SACRAMENTO COUNTY
MUNICIPAL SERVICES AGENCY

**GREY CAST IRON
STANDARD 36" MANHOLE
FRAME & COVER**

DRAWN BY: STAFF
SCALE: NONE
REVISION DATE: 08/10

9-10

SHEET 2 OF 2

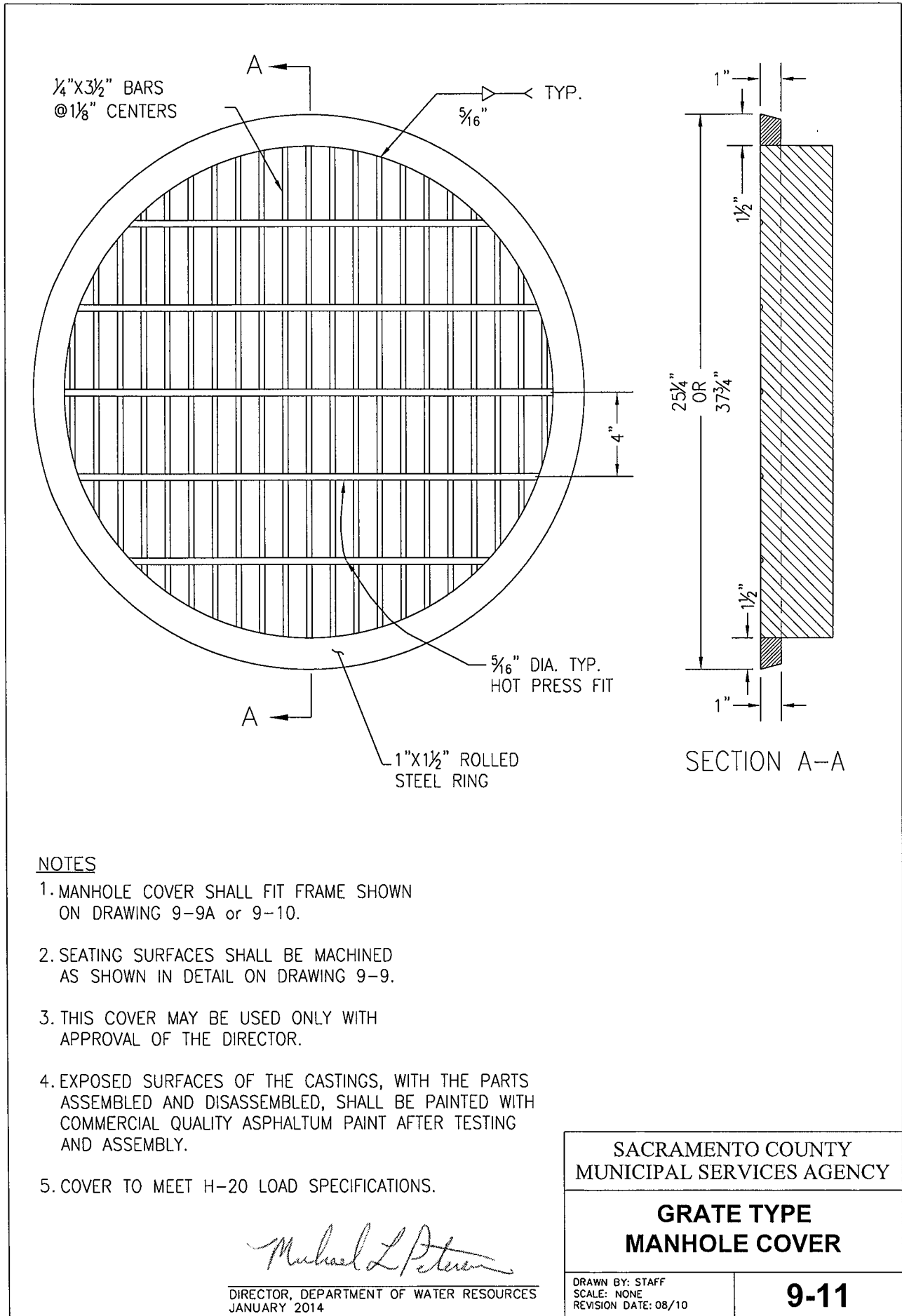

NOTES

1. MANHOLE COVER SHALL FIT FRAME SHOWN ON DRAWING 9-9A or 9-10.
2. SEATING SURFACES SHALL BE MACHINED AS SHOWN IN DETAIL ON DRAWING 9-9.
3. THIS COVER MAY BE USED ONLY WITH APPROVAL OF THE DIRECTOR.
4. EXPOSED SURFACES OF THE CASTINGS, WITH THE PARTS ASSEMBLED AND DISASSEMBLED, SHALL BE PAINTED WITH COMMERCIAL QUALITY ASPHALTUM PAINT AFTER TESTING AND ASSEMBLY.
5. COVER TO MEET H-20 LOAD SPECIFICATIONS.

Michael L. Peterson

DIRECTOR, DEPARTMENT OF WATER RESOURCES
JANUARY 2014

SACRAMENTO COUNTY MUNICIPAL SERVICES AGENCY	
GRATE TYPE MANHOLE COVER	
DRAWN BY: STAFF SCALE: NONE REVISION DATE: 08/10	9-11

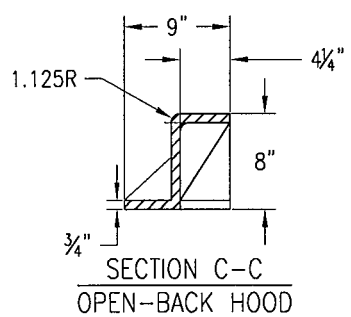
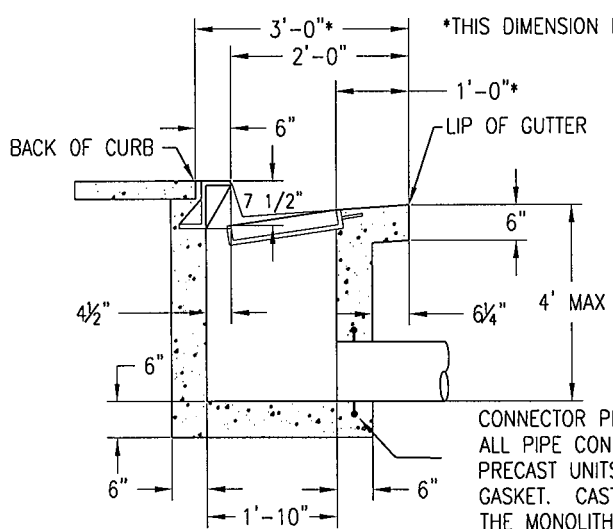
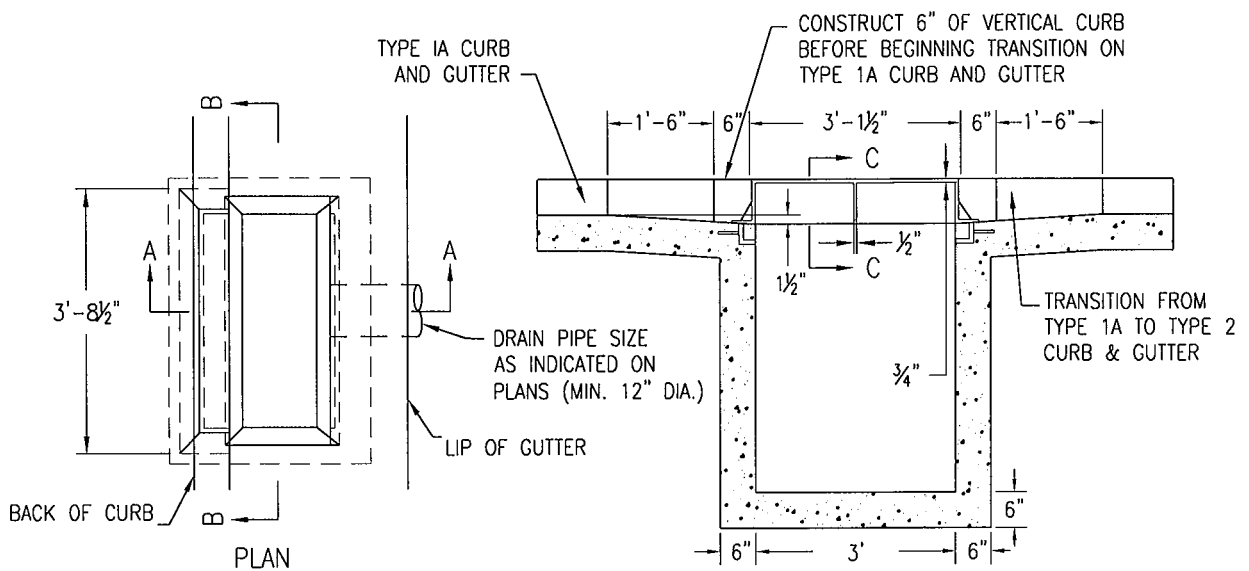

CONNECTOR PIPE OR MONOLITHIC CATCH BASIN CONNECTION (DRAWING 308-0). ALL PIPE CONNECTIONS SHALL CONFORM TO ASTM C-923. PRECAST UNITS SHALL BE BOOT TYPE OR INTEGRAL COMPRESSION GASKET. CAST IN PLACE UNITS SHALL INCLUDE A WATER STOP IF THE MONOLITHIC CATCH BASIN CONNECTION IS NOT REQUIRED.

SECTION A-A
TYPE 2-VERTICAL C&G

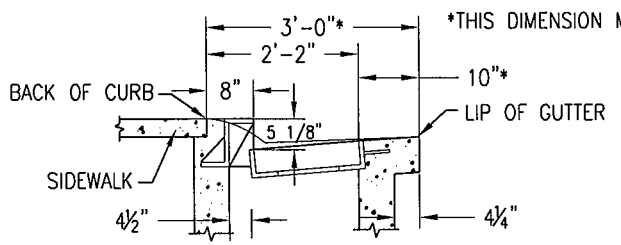

SECTION A-A
TYPE 1A-ROLLED C&G

NOTES

1. STANDARD DEPRESSION FOR INLET IS 1-1/2".
2. FRAME AND GRATE SHALL CONFORM TO DRAWINGS 9-14 AND 9-15.
3. OPEN-BACK HOOD SHALL BE H-20 RATED.
4. ALL EXPOSED EDGES SHALL HAVE A 1/8" R (MINIMUM).
5. AN EDGING TOOL SHALL BE USED ON ALL EDGES WHERE THE CONCRETE SIDEWALK AND CURB MEET THE TOP OF THE HOOD.
6. EXPOSED SURFACES OF THE GRATES, FRAMES AND HOODS WITH THE PARTS ASSEMBLED AND DISASSEMBLED SHALL BE PAINTED WITH COMMERCIAL QUALITY ASPHALTUM PAINT AFTER TESTING AND ASSEMBLY.
7. CAST IRON HOODS SHALL BE 3/4" THICK, NO GALVANIZING REQUIRED.

Michael L Peterson

DIRECTOR, DEPARTMENT OF WATER RESOURCES
JANUARY 2014

SACRAMENTO COUNTY
MUNICIPAL SERVICES AGENCY

**DROP INLET
TYPE B**

DRAWN BY: STAFF
SCALE: NONE
REVISION DATE: 10/09

9-13B

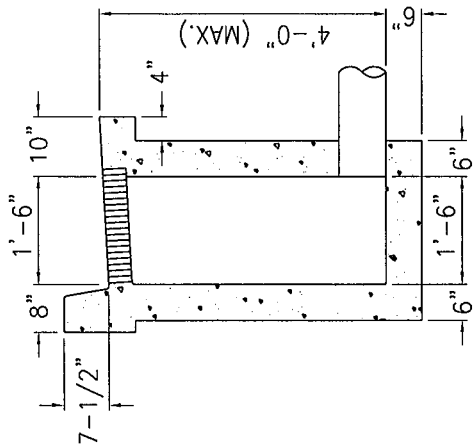

TYPE 2 CURB

SECTION A--A

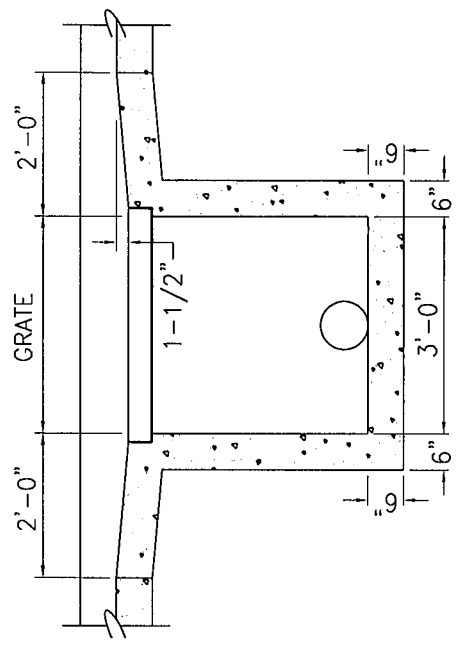
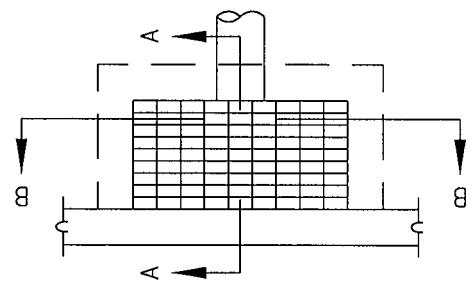

SECTION B--B

NOTES:

- 1 SEE DRAWINGS 9-14 AND 9-15 FOR FRAME AND GRATE DETAILS.
- 2 BOTTOM OF INLET SHALL BE PLACED PRIOR TO OR AT THE SAME TIME AS SIDE WALLS.
- 3 SEE NOTE 1 OF DRAWING 9-13B FOR GUTTER DEPRESSION.

Michael L. Peterson

DIRECTOR, DEPARTMENT OF WATER RESOURCES
JANUARY 2014

SACRAMENTO COUNTY
MUNICIPAL SERVICES AGENCY

**DROP INLET
TYPE C**

DRAWN BY: C. OREN
SCALE: NONE
REVISION DATE: 10/09

9-13C

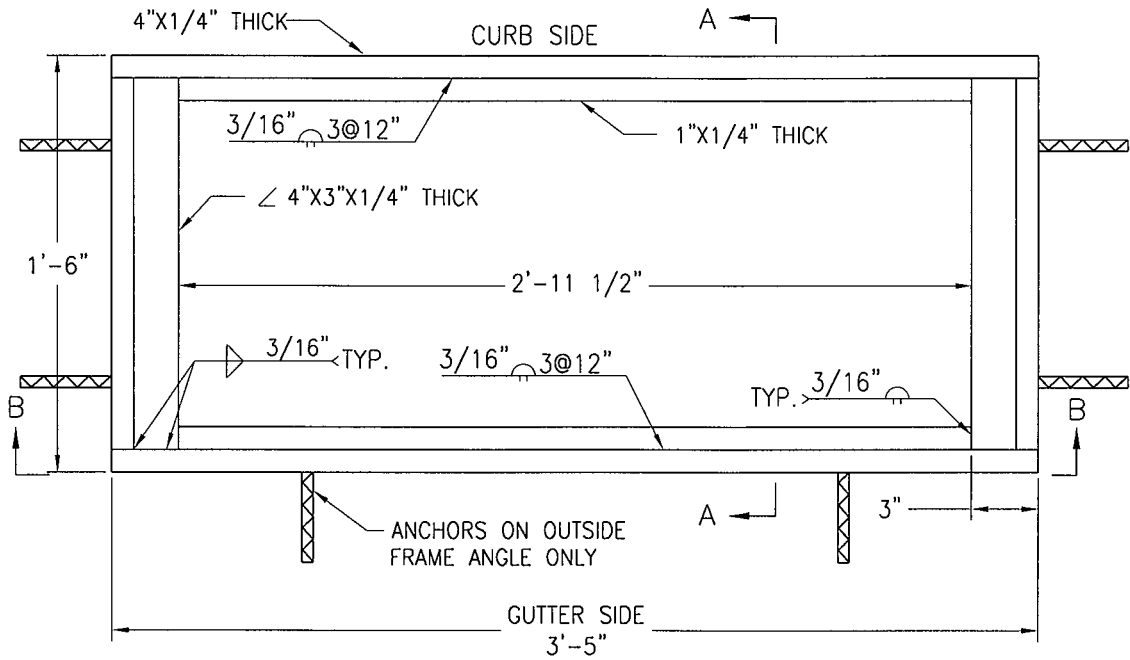

PLAN

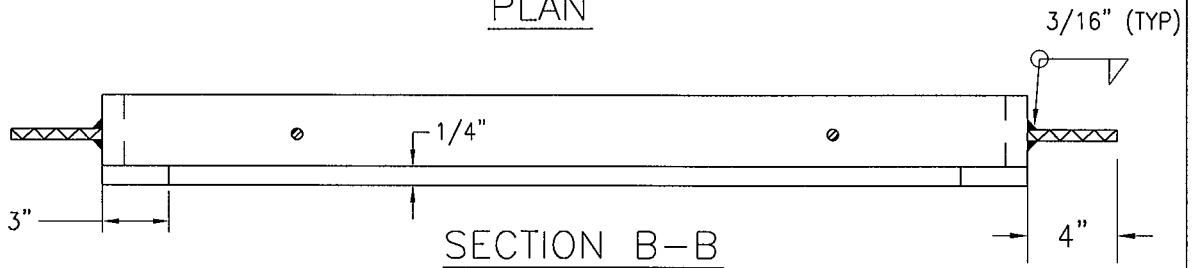

SECTION B-B

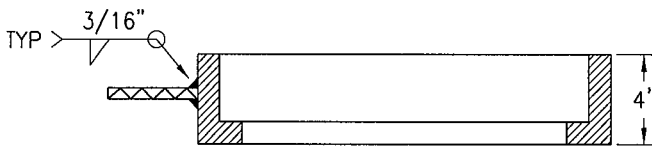

SECTION A-A

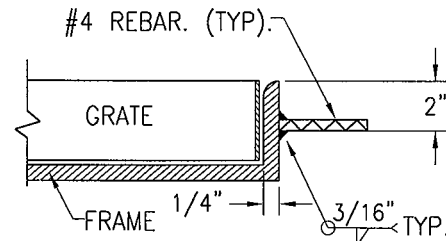

FRAME ANCHOR DETAIL

NOTES:

1. OMIT 1/2" FRAME ANCHORS OVER CENTER SUPPORT ASSEMBLY WHEN MULTIPLE FRAMES ARE USED.
2. MATERIAL: ASTM A36 MILD STEEL.
3. SEE ARTICLE 50-34, "SEWER AND STORM DRAIN CASTINGS," OF SECTION 50.
4. EXPOSED SURFACES OF THE GRATES, FRAMES AND HOODS WITH THE PARTS ASSEMBLED AND DISASSEMBLED SHALL BE PAINTED WITH COMMERCIAL QUALITY ASPHALTUM PAINT AFTER TESTING AND ASSEMBLY.

Michael L. Peters

DIRECTOR, DEPARTMENT OF WATER RESOURCES
JANUARY 2014

SACRAMENTO COUNTY
MUNICIPAL SERVICES AGENCY

**WELDED STEEL
GRATE FRAME**

DRAWN BY: L. PETERS
SCALE: NONE
REVISION DATE: 04/07

9-14

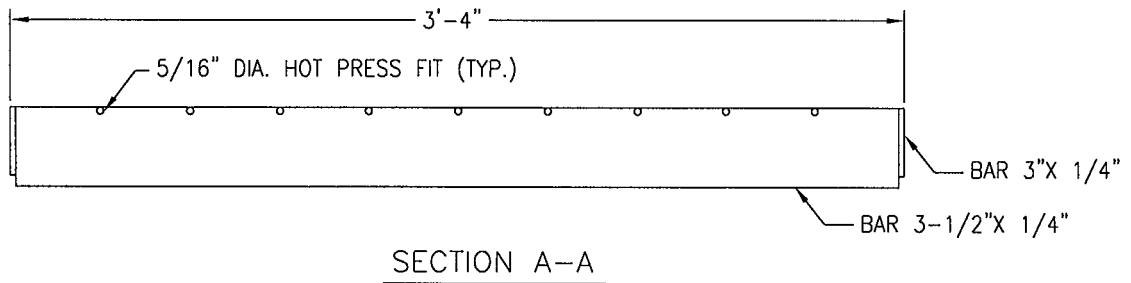
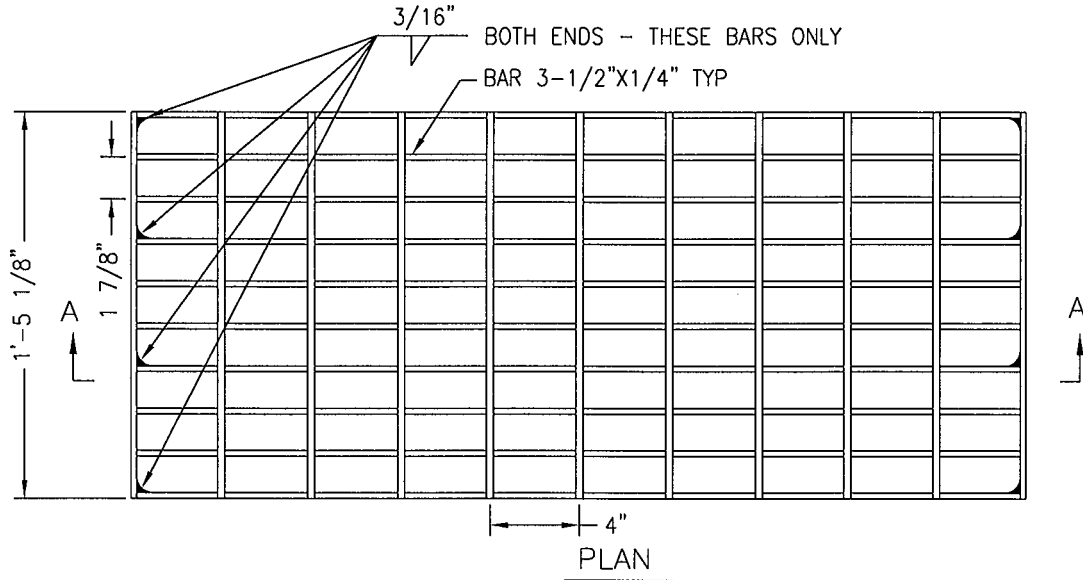

NOTES:

1. DIMENSIONS TO CENTERLINE OF BARS UNLESS OTHERWISE NOTED.
2. EXPOSED SURFACES OF THE GRATES, FRAMES AND HOODS, WITH THE PARTS ASSEMBLED AND DISASSEMBLED, SHALL BE PAINTED WITH COMMERCIAL QUALITY ASPHALTUM PAINT AFTER TESTING AND ASSEMBLY.

Michael L. Peterson

DIRECTOR, DEPARTMENT OF WATER RESOURCES
 JANUARY 2014

SACRAMENTO COUNTY
 MUNICIPAL SERVICES AGENCY

WELDED STEEL GRATE

DRAWN BY: M. FIELDS
 SCALE: NONE
 REVISION DATE: 04/07

9-15

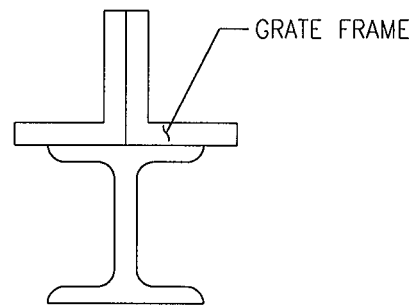
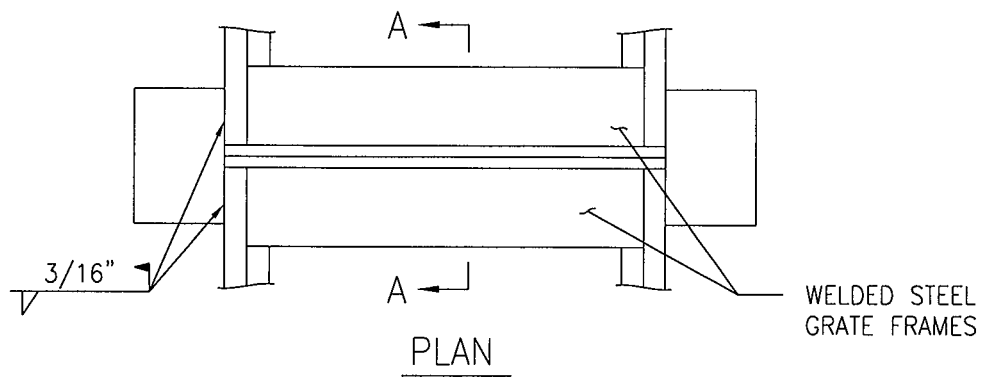

SECTION A-A

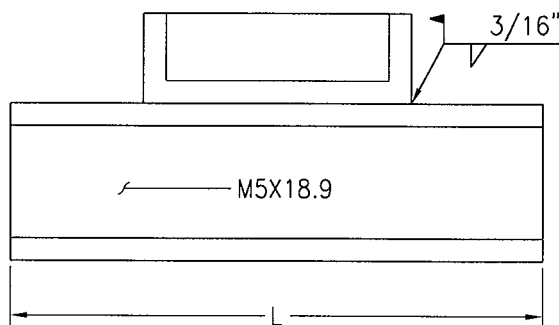

ELEVATION

NOTES:

1. OMIT 1/2" FRAME ANCHORS OVER CENTER SUPPORT
2. L=57 INCHES FOR CURB OPENING CATCH BASIN WITH GRATING(S) AND DEBRIS SKIMMER (STANDARD PLAN 301).
3. EXPOSED SURFACES OF THE GRATES , FRAMES AND HOODS, WITH PARTS ASSEMBLED AND DISASSEMBLED, SHALL BE PAINTED WITH COMMERCIAL QUALITY ASPHALTUM PAINT AFTER TESTING AND ASSEMBLY.

Michael L. Peterson

DIRECTOR, DEPARTMENT OF WATER RESOURCES
JANUARY 2014

SACRAMENTO COUNTY
MUNICIPAL SERVICES AGENCY

CENTER SUPPORT
ASSEMBLY FOR
MULTIPLE GRATES

DRAWN BY: M. FIELDS
SCALE: NONE
REVISION DATE: 04/07

9-16

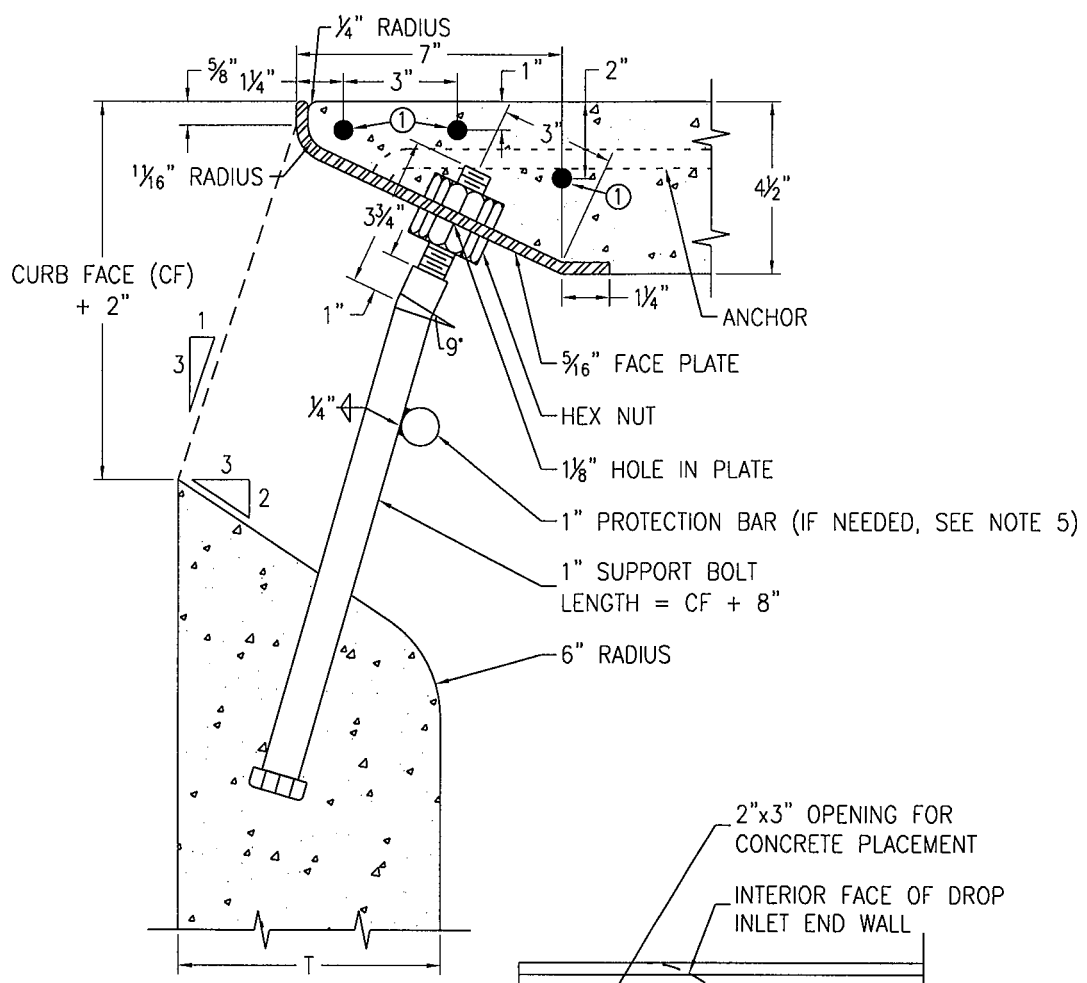

① #4 BAR x W+6". IN ADDITION TO REINFORCING STEEL PER DRAWING 301-1.

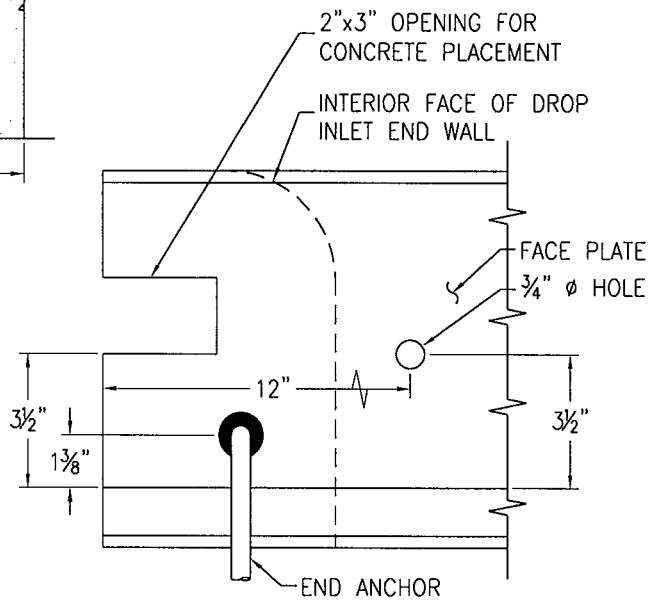

END DETAIL

Michael L. Peterson

DIRECTOR, DEPARTMENT OF WATER RESOURCES
JANUARY 2014

SACRAMENTO COUNTY
MUNICIPAL SERVICES AGENCY
**CATCH BASIN FACE PLATE
ASSEMBLY AND
PROTECTION BAR**

DRAWN BY: S. PIMENTEL
SCALE: NONE
REVISION DATE: 5/12

9-17
SHEET 1 OF 2

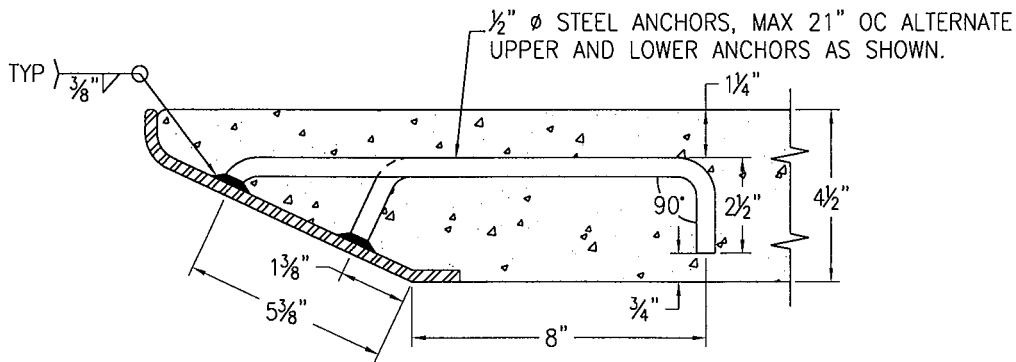

FACE PLATE ANCHORS

GENERAL NOTES:

1. TO BE USED ONLY IN TYPE 2 CURB AND GUTTER WITH A 2" DEPRESSION. USE IN TYPE 1A CURB AND GUTTER ONLY UPON APPROVAL OF THE DIRECTOR. ALTERNATE ANGLE IRON SIZE, DEPRESSION DEPTH, AND SLAB THICKNESS MAY BE USED UPON APPROVAL OF THE DIRECTOR.
2. ALL PARTS SHALL BE STEEL, EXCEPT SET SCREWS, WHICH SHALL BE STAINLESS STEEL OR BRASS.
3. EXPOSED SURFACES OF THE GRATES, FRAMES AND HOODS WITH THE PARTS ASSEMBLED AND DISASSEMBLED SHALL BE PAINTED WITH COMMERCIAL QUALITY ASPHALTUM PAINT AFTER TESTING AND ASSEMBLY.
4. FACE PLATE LENGTHS SHALL BE CAST INTO THE STRUCTURE CONTINUOUS FOR THE FULL LENGTH + 12".
5. WHEN CURB INLET OPENING HEIGHT EXCEEDS: 6" INSTALL 1" ϕ STEEL PROTECTION BAR, 12" INSTALL 2-1" ϕ STEEL PROTECTION BARS (EQUALLY SPACED), 17" INSTALL 3-1" ϕ STEEL PROTECTION BARS (EQUALLY SPACED).
6. WHEN CURB INLET OPENING LENGTH EXCEEDS 7' INSTALL 1" ϕ STEEL SUPPORT BOLTS, SPACED AT NOT MORE THAN 5' O.C.
7. ALTERNATE ANGLE IRON SIZE, DEPRESSION DEPTH, AND SLAB THICKNESS MAY BE USED UPON APPROVAL OF THE DIRECTOR.
8. TOP SLAB OVER INLET SHALL BE 4 1/2".

Michael L. Peters

DIRECTOR, DEPARTMENT OF WATER RESOURCES
JANUARY 2014

SACRAMENTO COUNTY
MUNICIPAL SERVICES AGENCY

**CATCH BASIN FACE PLATE
ASSEMBLY AND
PROTECTION BAR**

DRAWN BY: S. PIMENTEL
SCALE: NONE
REVISION DATE: 10/09

9-17
SHEET 2 OF 2

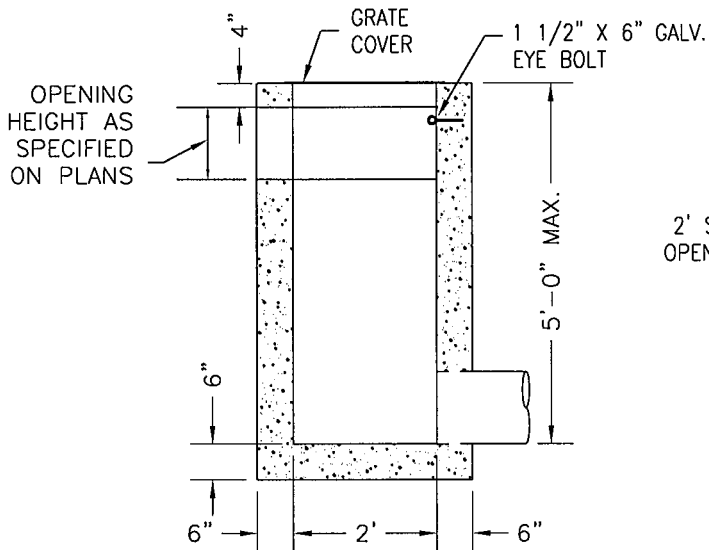

SECTION A-A

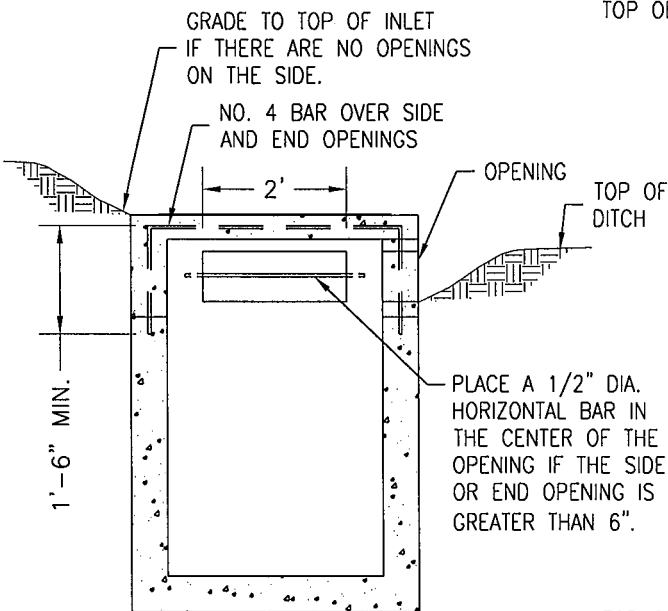
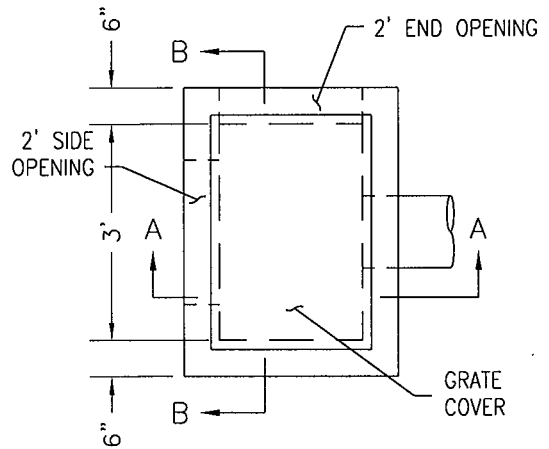

SECTION B-B

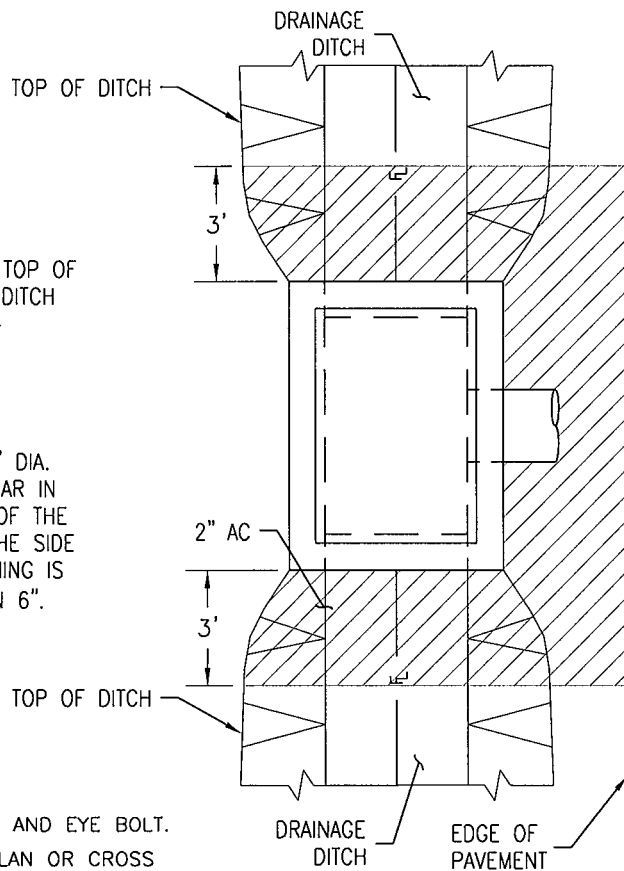

NOTES:

1. PROVIDE 1/4" X 18" GALV. CHAIN WELD TO COVER AND EYE BOLT.
2. PROVIDE END OR SIDE OPENINGS AS SHOWN ON PLAN OR CROSS SECTION.
3. TOP OF ALL WALLS TO BE FINISHED TO A FLAT PLANE TO PROVIDE EVEN BEARING FOR THE GRATE COVER.
4. ALL METAL SHALL BE GALVANIZED PER ASTM A123.
5. INSTALL A GREEN CARSONITE UTILITY MARKER PRODUCT NUMBER CRM306607 OR EQUIVALENT. UTILITY MARKER SHALL HAVE A 3"X12" SILVER/WHITE HIGH INTENSITY STRIP ON THE FRONT AND A 3"X3" SILVER/WHITE HIGH INTENSITY STRIP ON THE BACK. INSTALL THE UTILITY MARKER PER MANUFACTURER'S STANDARDS. THE MARKER SHALL BE INSTALLED 1' FROM THE EDGE OF PAVEMENT AT THE CENTERLINE OF THE DROP INLET.

Michael L. Peterson

DIRECTOR, DEPARTMENT OF WATER RESOURCES
JANUARY 2014

SACRAMENTO COUNTY
MUNICIPAL SERVICES AGENCY

**DROP INLET
TYPE F**

DRAWN BY: STAFF
SCALE: NONE
REVISION DATE: 10/09

9-18
SHEET 1 OF 2

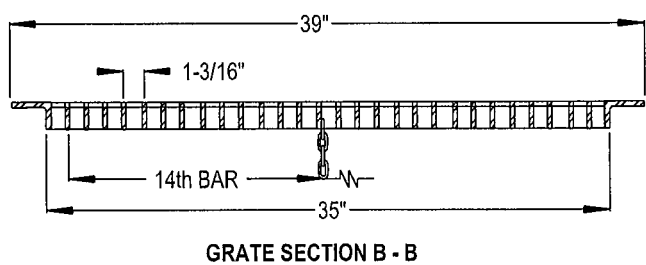
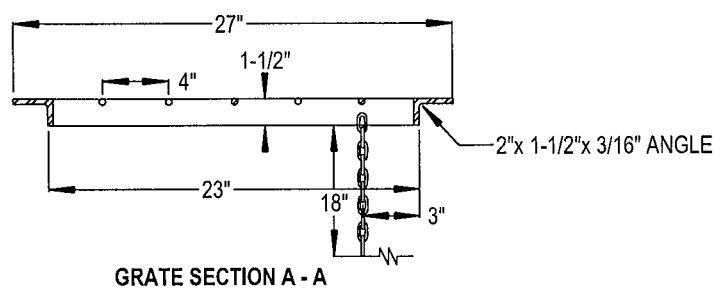
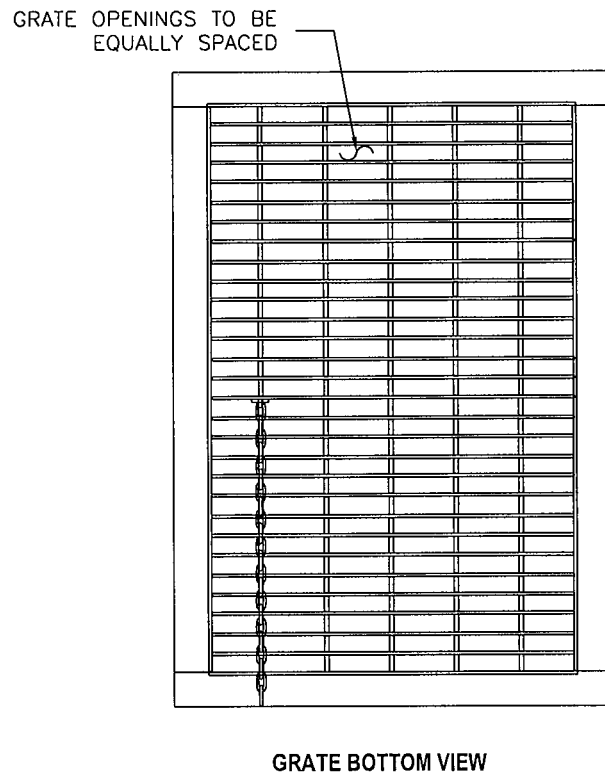
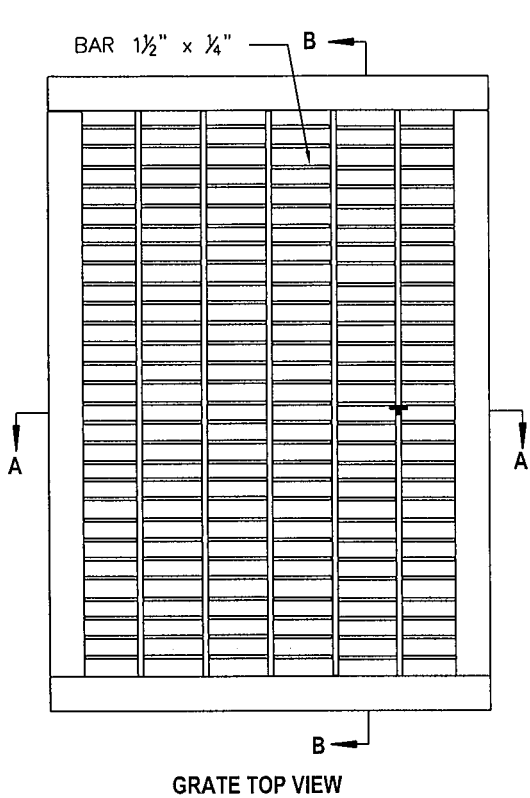

SACRAMENTO COUNTY
MUNICIPAL SERVICES AGENCY

**DROP INLET
TYPE F**

DRAWN BY: S. PIMENTEL
SCALE: NONE
REVISION DATE: 04/07

9-18
SHEET 2 OF 2

Michael L. Peterson

DIRECTOR, DEPARTMENT OF WATER RESOURCES
JANUARY 2014

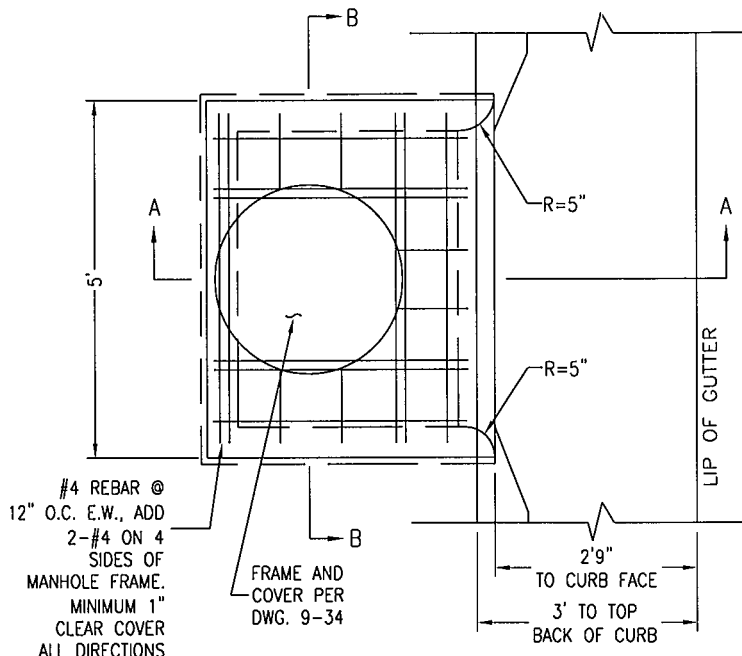

PLAN

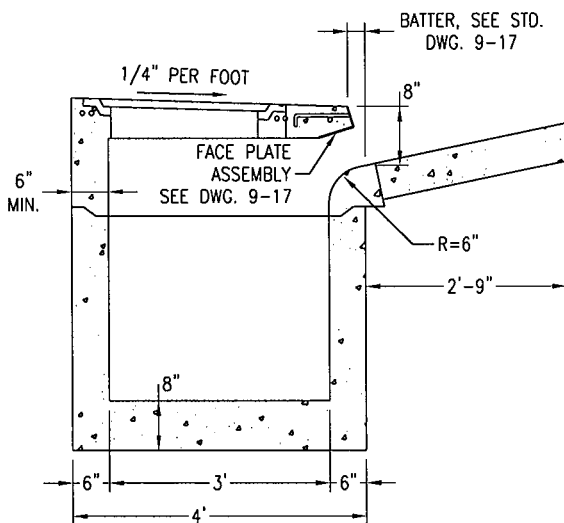

SECTION A-A

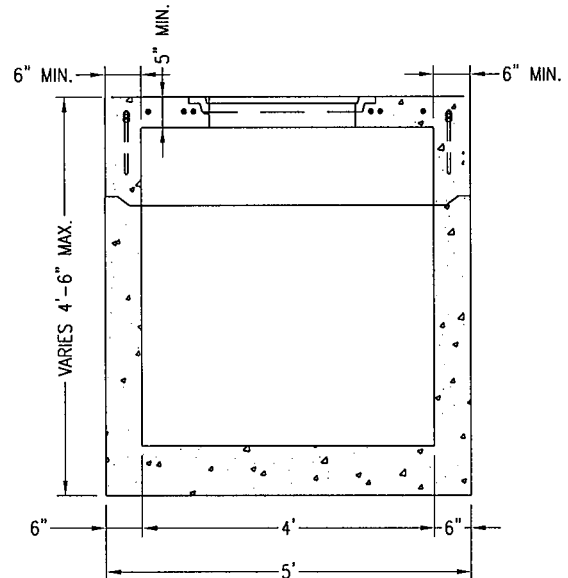

SECTION B-B

NOTES:

1. CURB INLET ASSEMBLY MAY BE PRECAST CONCRETE, OR FORMED AND CAST-IN-PLACE P.C.C.
2. EXPOSED SURFACES OF THE GRATES, FRAMES AND HOODS, WITH THE PARTS ASSEMBLED AND DISASSEMBLED, SHALL BE PAINTED WITH COMMERCIAL QUALITY ASPHALTUM PAINT AFTER TESTING AND ASSEMBLY.
3. SEE STD. DWG. 9-17 FOR FACE PLATE ASSEMBLY.

Michael L. Peterson

DIRECTOR, DEPARTMENT OF WATER RESOURCES
JANUARY 2014

SACRAMENTO COUNTY
MUNICIPAL SERVICES AGENCY

**DROP INLET
TYPE G**

DRAWN BY: STAFF
SCALE: NONE
REVISION DATE: 10/09

9-19
SHEET 1 OF 3

FOR VERTICAL CURB (TYPE 2)

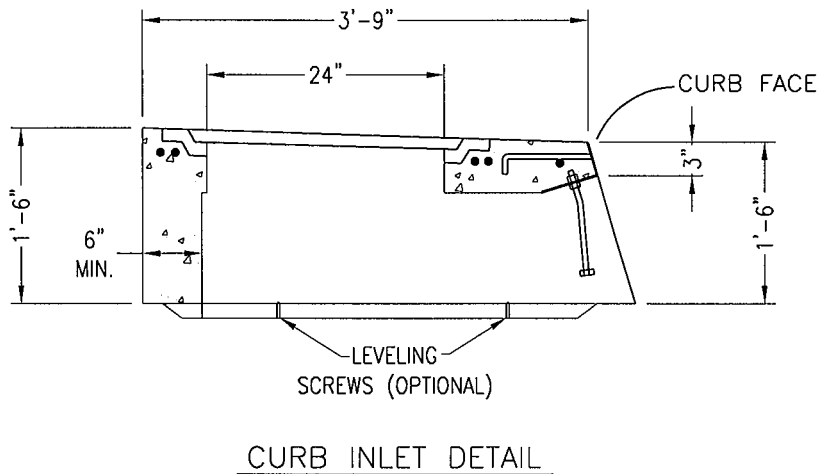
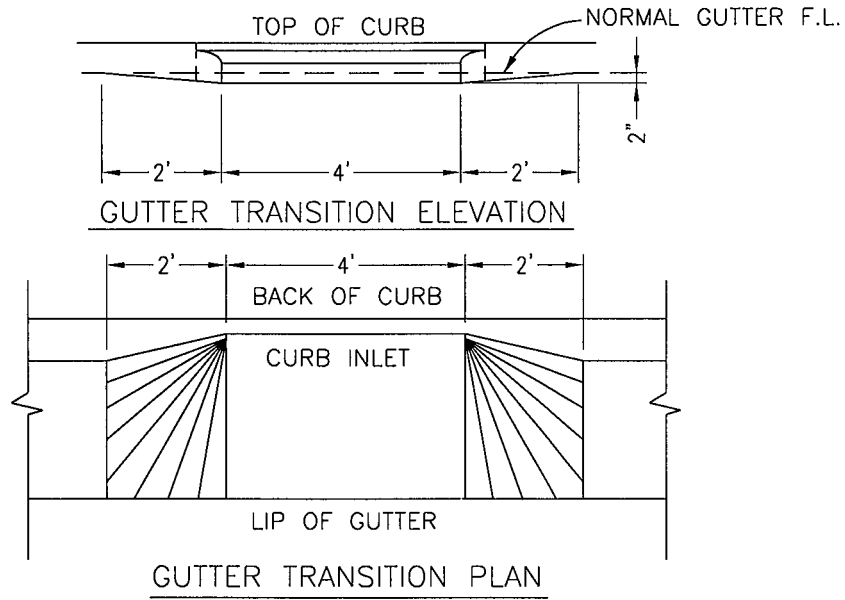

NOTES:

1. CURB INLET ASSEMBLY MAY BE PRECAST CONCRETE, OR FORMED AND CAST-IN-PLACE P.C.C.
2. EXPOSED SURFACES OF THE GRATES, FRAMES AND HOODS, WITH THE PARTS ASSEMBLED AND DISASSEMBLED, SHALL BE PAINTED WITH COMMERCIAL QUALITY ASPHALTUM PAINT AFTER TESTING AND ASSEMBLY.

Michael L. Peterson

DIRECTOR, DEPARTMENT OF WATER RESOURCES
JANUARY 2014

SACRAMENTO COUNTY
MUNICIPAL SERVICES AGENCY

DROP INLET
TYPE G
Type 2 C & G

DRAWN BY: STAFF
SCALE: NONE
REVISION DATE: 10/09

9-19
SHEET 2 OF 3

FOR ROLLED CURB (TYPE 1A)

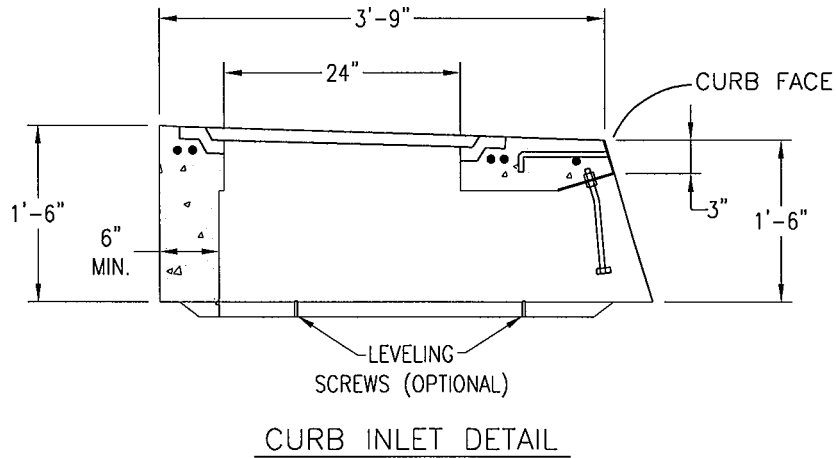
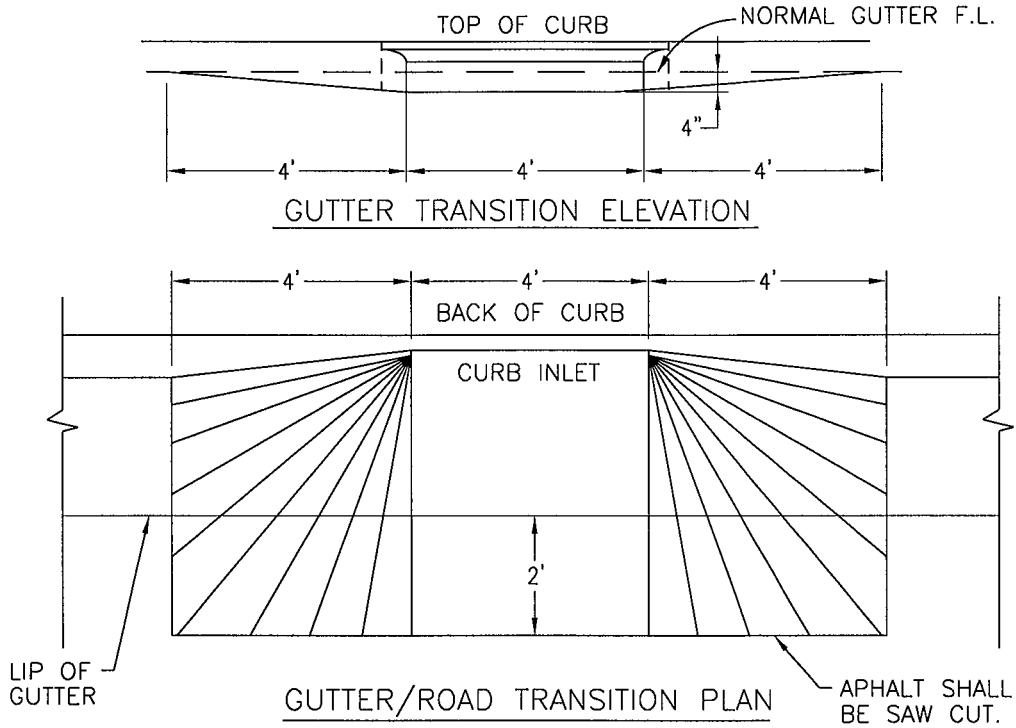

NOTES:

1. CURB INLET ASSEMBLY MAY BE PRECAST CONCRETE, OR FORMED AND CAST-IN-PLACE P.C.C.
2. EXPOSED SURFACES OF THE GRATES, FRAMES AND HOODS, WITH THE PARTS ASSEMBLED AND DISASSEMBLED, SHALL BE PAINTED WITH COMMERCIAL QUALITY ASPHALTUM PAINT AFTER TESTING AND ASSEMBLY.
3. USE OF TYPE G INLET IN TYPE 1A C&G ONLY WITH APPROVAL FROM THE DIRECTOR.

Michael L. Peterson

DIRECTOR, DEPARTMENT OF WATER RESOURCES
JANUARY 2014

SACRAMENTO COUNTY
MUNICIPAL SERVICES AGENCY

DROP INLET
TYPE G
Type 1A C & G

DRAWN BY: STAFF
SCALE: NONE
REVISION DATE: 10/09

9-19
SHEET 3 OF 3

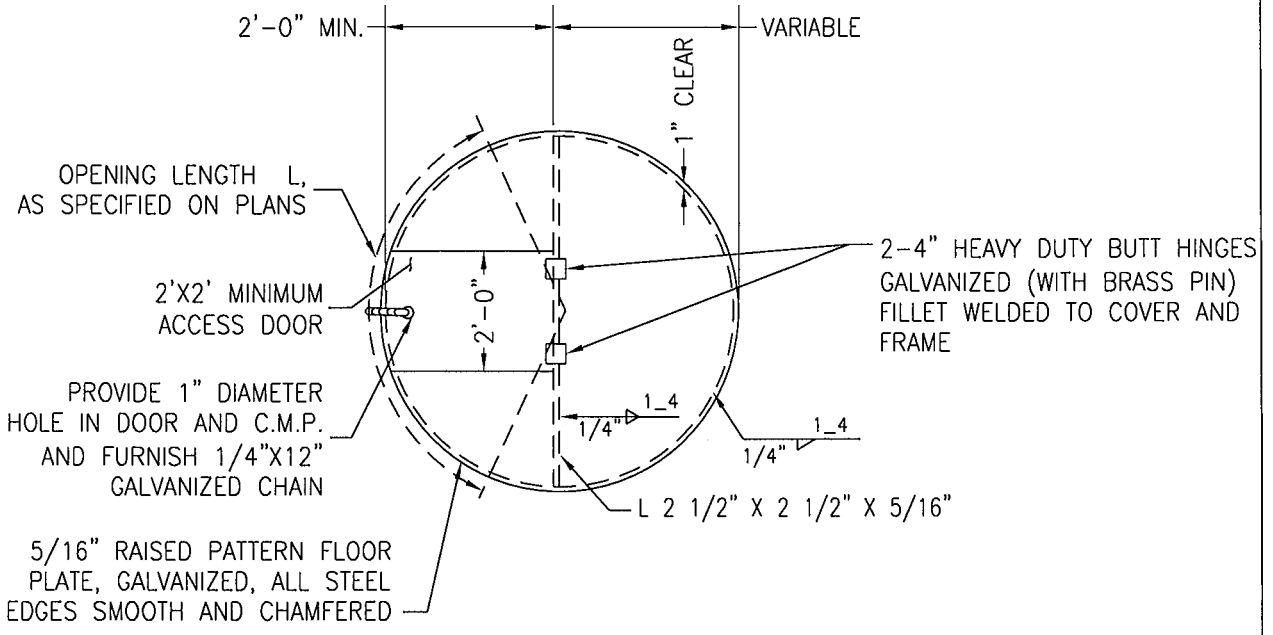

PLAN
42" DIAMETER TO 72" DIAMETER
C.M.P. INLET

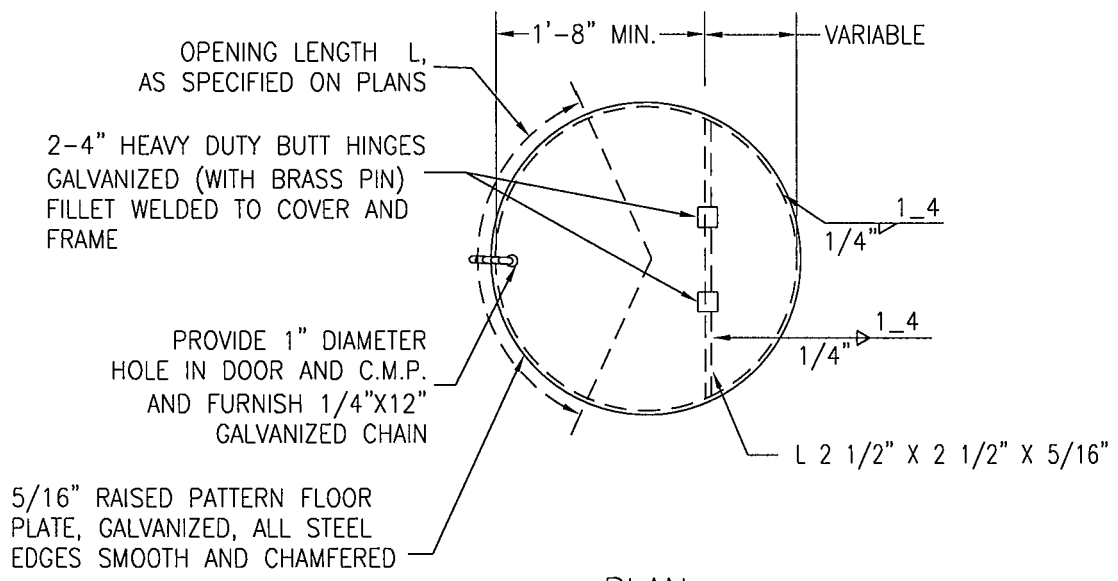

PLAN
24" DIAMETER TO 36" DIAMETER
C.M.P. INLET

Michael L. Peterson

DIRECTOR, DEPARTMENT OF WATER RESOURCES
JANUARY 2014

SACRAMENTO COUNTY MUNICIPAL SERVICES AGENCY	
CORRUGATED METAL PIPE DRAINAGE INLET TYPE I	
DRAWN BY: M. FIELDS SCALE: NONE REVISION DATE: 10/09	9-20 SHEET 1 OF 2

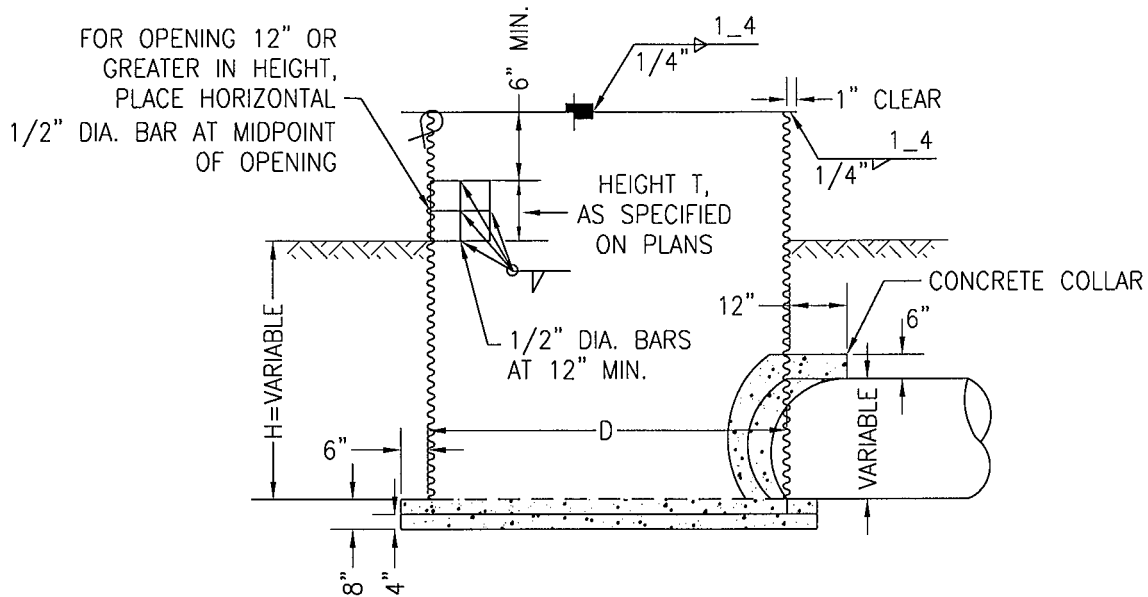

SECTION
24" DIAMETER TO 36" DIAMETER
C.M.P. INLET

NOTES

1. LOCATIONS, HEIGHTS, AND LENGTH OF OPENINGS SHALL BE AS SHOW ON THE PLANS.
2. AREA OF THE OPENING SHALL NOT BE LESS THAN THE AREA OF OUTFALL PIPE.
3. OUTFALL PIPE TO BE CUT FLUSH WITH INSIDE OF RISER.
4. NOT TO BE USED AS A JUNCTION STRUCTURE.
5. DIAMETER OF RISER PIPE SHALL BE AT LEAST ONE SIZE LARGER THAN OUTFALL PIPE.
6. TO BE USED ONLY WITH THE SPECIFIC APPROVAL OF THE DIRECTOR.
7. INSTALL A GREEN CARSONITE UTILITY MARKER PRODUCT NUMBER CRM306607 OR EQUIVALENT. UTILITY MARKER SHALL HAVE A 3"x12" SILVER/WHITE HIGH INTENSITY STRIP ON THE FRONT AND A 3"x3" SILVER/WHITE HIGH INTENSITY STRIP ON THE BACK. INSTALL THE UTILITY MARKER PER MANUFACTURER'S STANDARDS. THE POST SHALL BE INSTALLED 1' FROM THE EDGE OF PAVEMENT AT THE CENTERLINE OF THE DROP INLET.

RISER DIAMETER, D	H, MAX.	HEIGHT T, MAX.	GAGES (MINIMUM)
24"	4'	8"	0.079"
30"	4'	8"	0.079"
36"	5'	8"	0.109"
42"	8'	12"	0.109"
48"	8'	12"	0.109"
54"	10'	18"	0.109"
60"	10'	18"	0.109"
72"	10'	18"	0.109"

Michael L. Peterson

DIRECTOR, DEPARTMENT OF WATER RESOURCES
JANUARY 2014

SACRAMENTO COUNTY
MUNICIPAL SERVICES AGENCY
**CORRUGATED METAL PIPE
DRAINAGE INLET
TYPE I**

DRAWN BY: STAFF
SCALE: NONE
REVISION DATE: 10/09

9-20
SHEET 2 OF 2

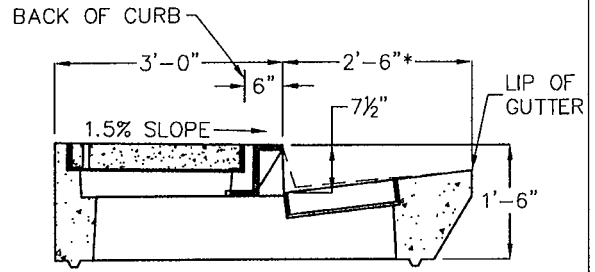
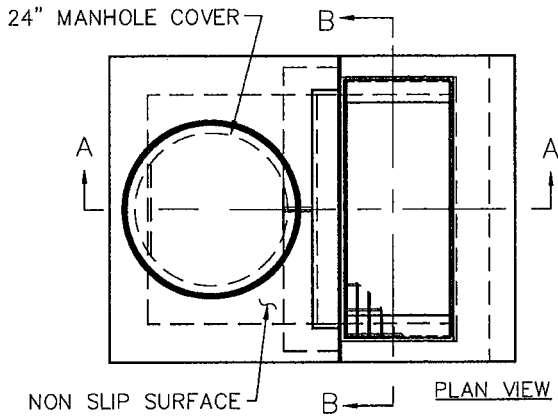

SECTION A-A

TYPE 2 - VERTICAL CURB & GUTTER
(FOR INFORMATION NOT SHOWN OR NOTED REFER TO SECTION A-A TYPE 1A CURB & GUTTER)

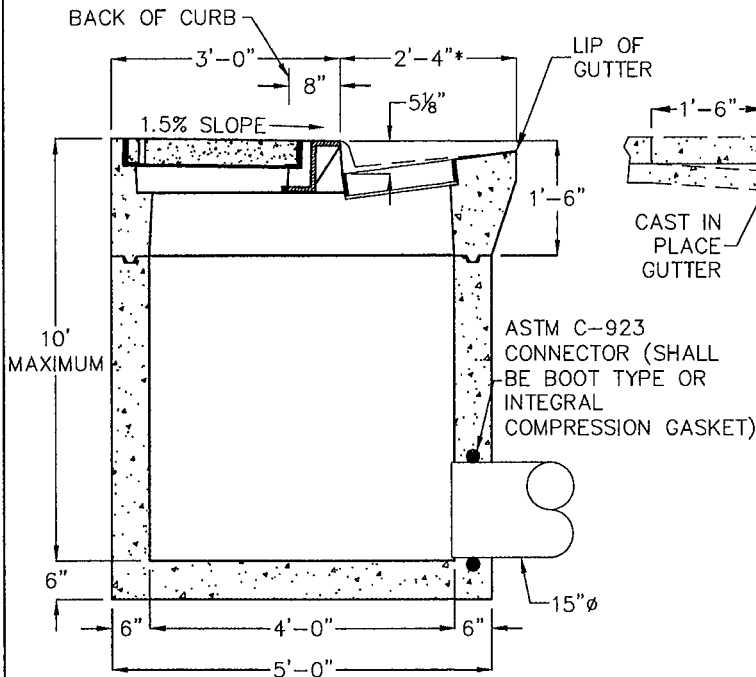

SECTION A-A

TYPE 1A - ROLLED CURB & GUTTER

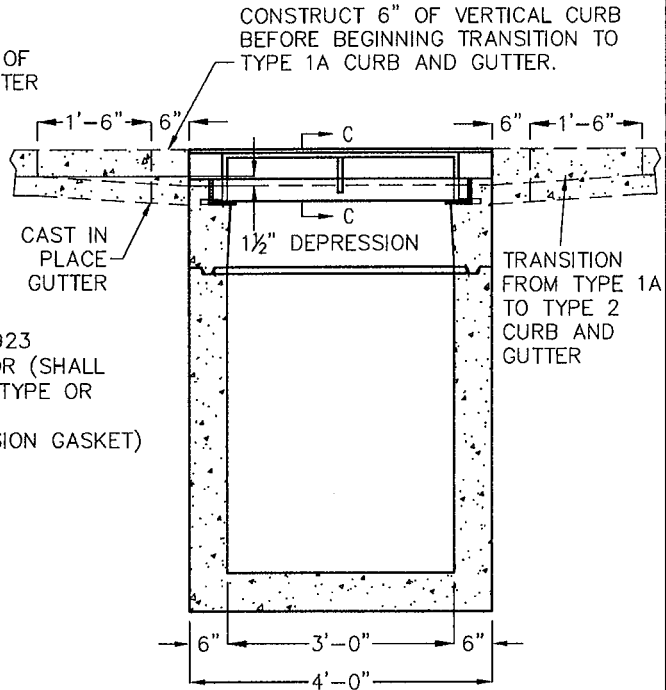

SECTION B-B

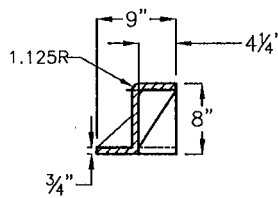

SECTION C-C
OPEN-BACK HOOD

*THIS DIMENSION MAY VARY WITHIN EXISTING STREETS.

NOTES:

1. STANDARD DEPRESSION FOR INLET IS 1 1/2".
2. MANHOLE FRAME AND COVER SHALL CONFORM TO DRAWING 9-36.
3. FRAME AND GRATE SHALL CONFORM TO DRAWINGS 9-14 AND 9-15.
4. ALL EXPOSED EDGES SHALL HAVE A 1/8" RADIUS (MINIMUM).
5. AN EDGING TOOL SHALL BE USED ON ALL EDGES WHERE THE CONCRETE SIDEWALK AND CURB MEET THE TOP OF THE HOOD.
6. EXPOSED SURFACES OF THE GRATE, FRAMES AND HOOD WITH THE PARTS ASSEMBLED AND DISASSEMBLED SHALL BE PAINTED WITH COMMERCIAL QUALITY ASPHALTUM PAINT AFTER TESTING AND ASSEMBLY OR GALVANIZED.
7. INLET SHALL NOT BE CAST IN PLACE.

Michael Peter

DIRECTOR, DEPARTMENT OF WATER RESOURCES
NOVEMBER 2015

SACRAMENTO COUNTY
MUNICIPAL SERVICES AGENCY

PRECAST DROP INLET
TYPE J

DRAWN BY: STAFF
SCALE: NONE
DATE: 10/15

9-21

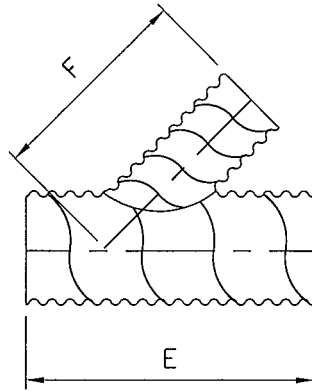

WYE LATERAL

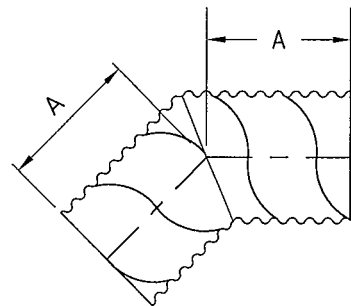

ELBOW
0° to 45°

FITTING SIZES

DIA (in)	A (ft)	E (ft)	F (ft)
12	1	4	2
15	1	4	4
18	1	4	4
21	2	6	4
24	2	6	4
30	2	6	4
36	2	8	6
42	2	8	6
48	2	10	8
54	3	10	8
60	3	12	10
66	3	12	10
72	3	14	10
78	3	14	10
84	3	16	12
90	3	16	12
96	3	16	12

NOTES

1. To use table, refer to diagram and select letter representing desired dimension, then enter table at correct pipe dimension and read dimension in column under appropriate letter heading.
2. Dimensions on table allow for use of standard 12 inch wide band coupler on sizes 12 inch through 54 inch and 24 inch wide band on 60 inch and larger sizes.
3. For pipe-arch fittings, choose pipe diameter equal to or greater than arch span. (Example: 35 inch x 24 inch pipe-arch; use dimensions for 36 inch pipe).
4. Structural reinforcement may be required on some larger sizes.

Michael L. Peters

DIRECTOR, DEPARTMENT OF WATER RESOURCES
JANUARY 2014

SACRAMENTO COUNTY
MUNICIPAL SERVICES AGENCY

CORRUGATED PIPE FITTINGS

DRAWN BY: C. SCHUMAKER
SCALE: NONE
REVISION DATE: 11/98

9-22

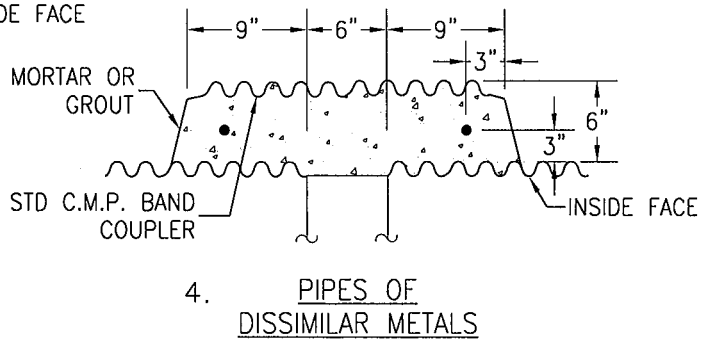
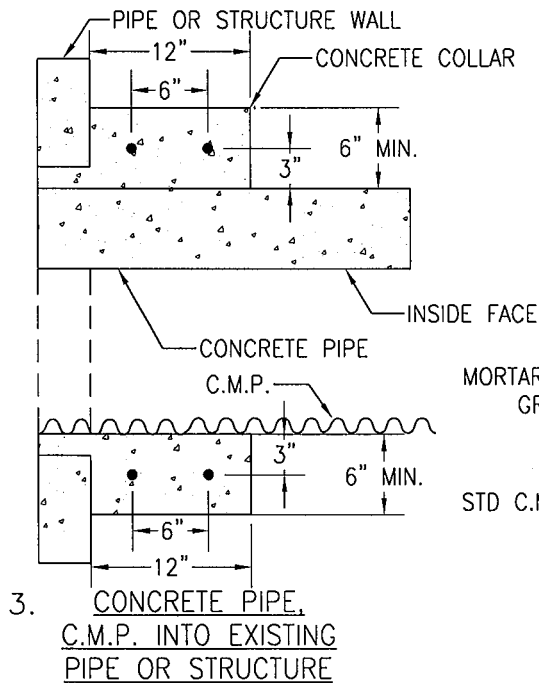
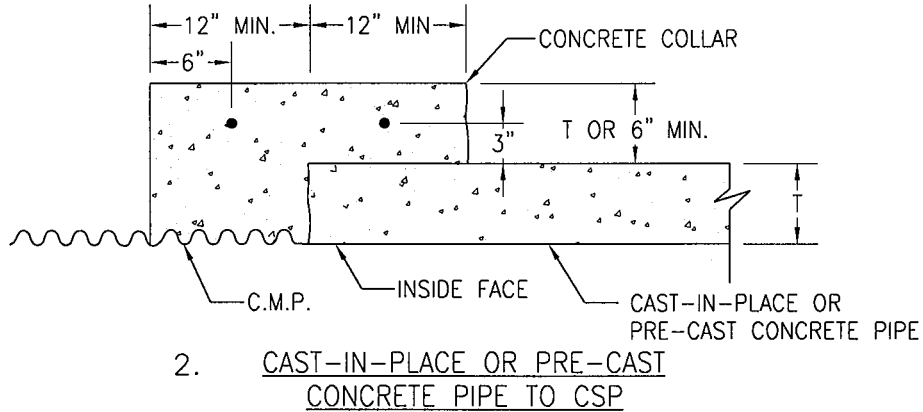
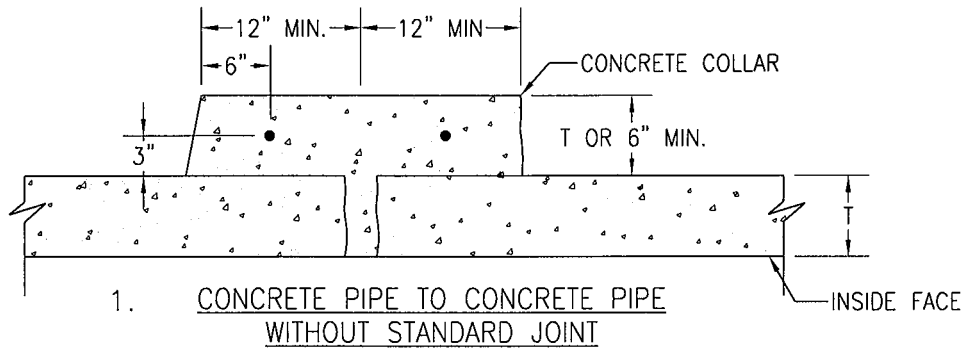

NOTES:

1. TO CONNECT HDPE TYPE S OR D PIPE TO OTHER PIPES USE COLLAR SHOWN IN DETAIL 1 OR USE MANUFACTURERS STANDARD HDPE REPAIR COUPLING.

2. ALL REINFORCEMENT SHALL BE #3 REBAR.

Michael L. Peterson

DIRECTOR, DEPARTMENT OF WATER RESOURCES
JANUARY 2014

SACRAMENTO COUNTY
MUNICIPAL SERVICES AGENCY

PIPE CONNECTIONS

DRAWN BY: M.FIELDS
SCALE: NONE
REVISION DATE: 1/03

9-23

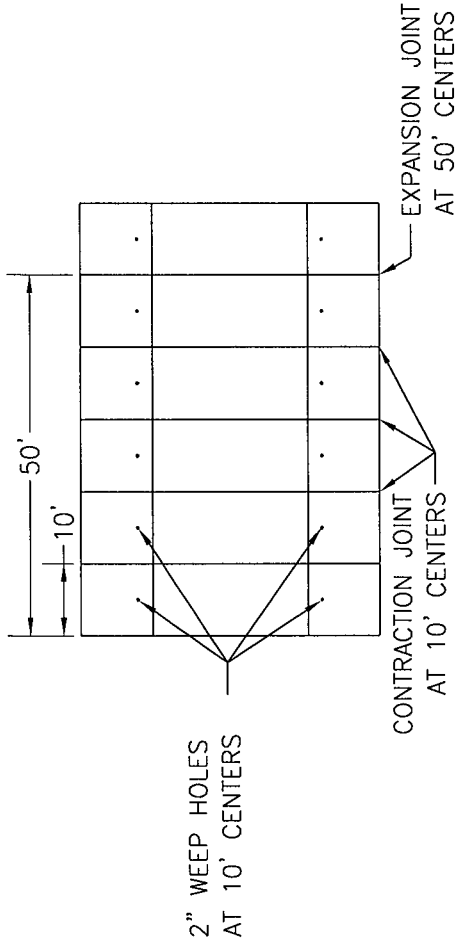

PLAN VIEW

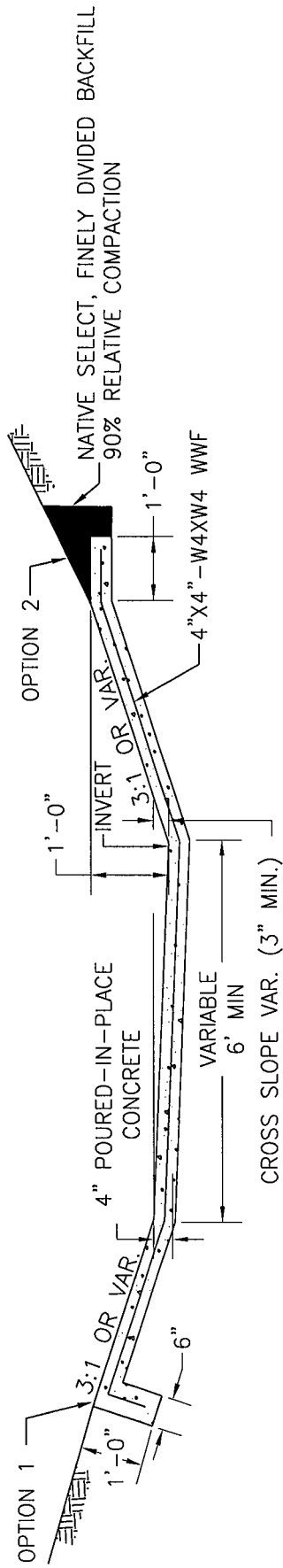

TYPICAL BOTTOM LINING

SACRAMENTO COUNTY
MUNICIPAL SERVICES AGENCY

LINED CHANNEL SECTION

Michael L. Peterson

DIRECTOR, DEPARTMENT OF WATER RESOURCES
JANUARY 2014

DRAWN BY: MYRA FIELDS
SCALE: NONE
REVISION DATE: 10/09

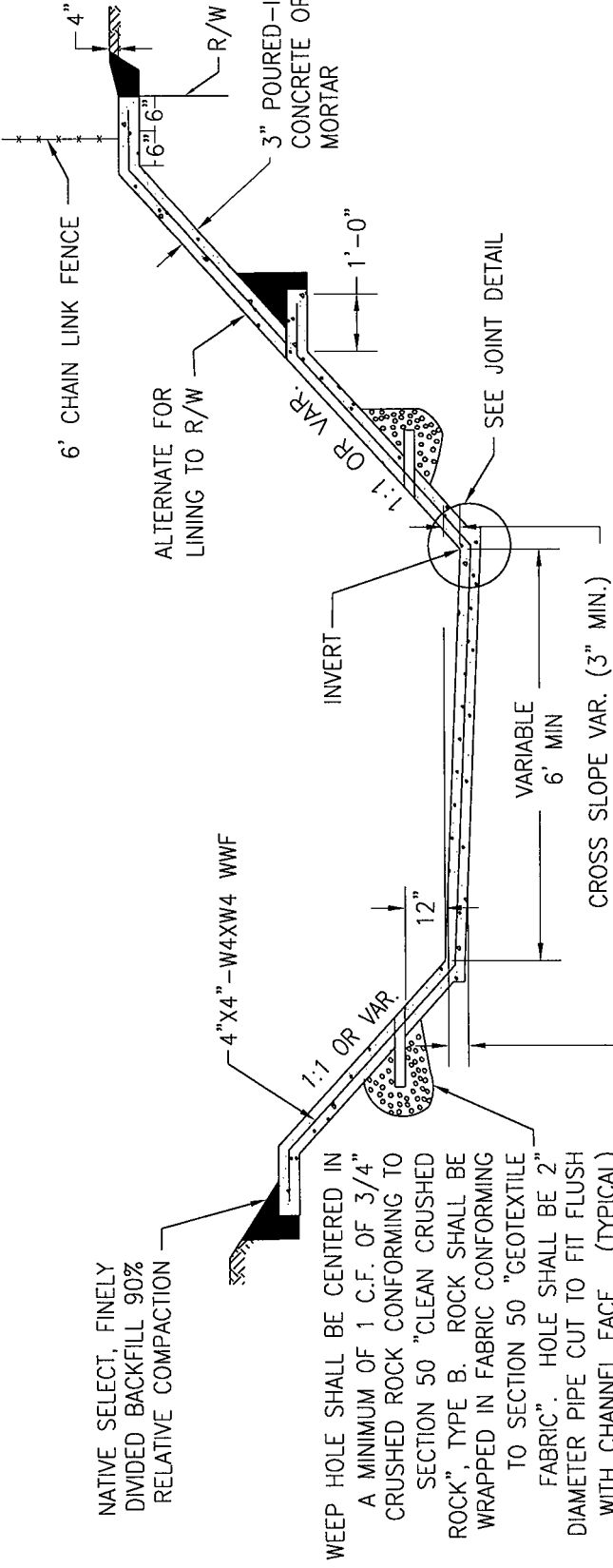

NATIVE SELECT, FINELY DIVIDED BACKFILL 90% RELATIVE COMPACTION

WEEP HOLE SHALL BE CENTERED IN A MINIMUM OF 1 C.F. OF 3/4" CRUSHED ROCK CONFORMING TO SECTION 50 "CLEAN CRUSHED ROCK", TYPE B. ROCK SHALL BE WRAPPED IN FABRIC CONFORMING TO SECTION 50 "GEOTEXTILE FABRIC". HOLE SHALL BE 2" DIAMETER PIPE CUT TO FIT FLUSH WITH CHANNEL FACE. (TYPICAL)

4" POURED-IN-PLACE CONCRETE

TYPICAL FULL LINING

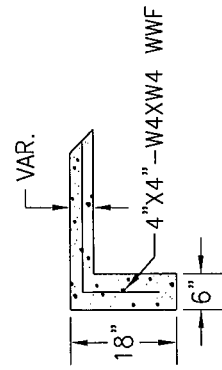

CUTOFF WALL TO BE PLACED ALONG ENTIRE END OF LINED SECTION AT BEGINNING AND AT END OF LINING

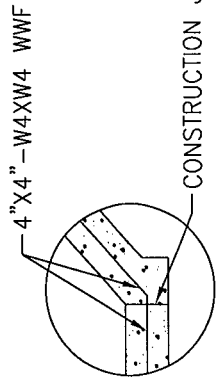

JOINT DETAIL

SACRAMENTO COUNTY MUNICIPAL SERVICES AGENCY

LINED CHANNEL SECTION

DRAWN BY: MYRA FIELDS
SCALE: NONE
REVISION DATE: 10/09

DIRECTOR, DEPARTMENT OF WATER RESOURCES
JANUARY 2014

Michael L. Peterson

9-24
SHEET 2 OF 2

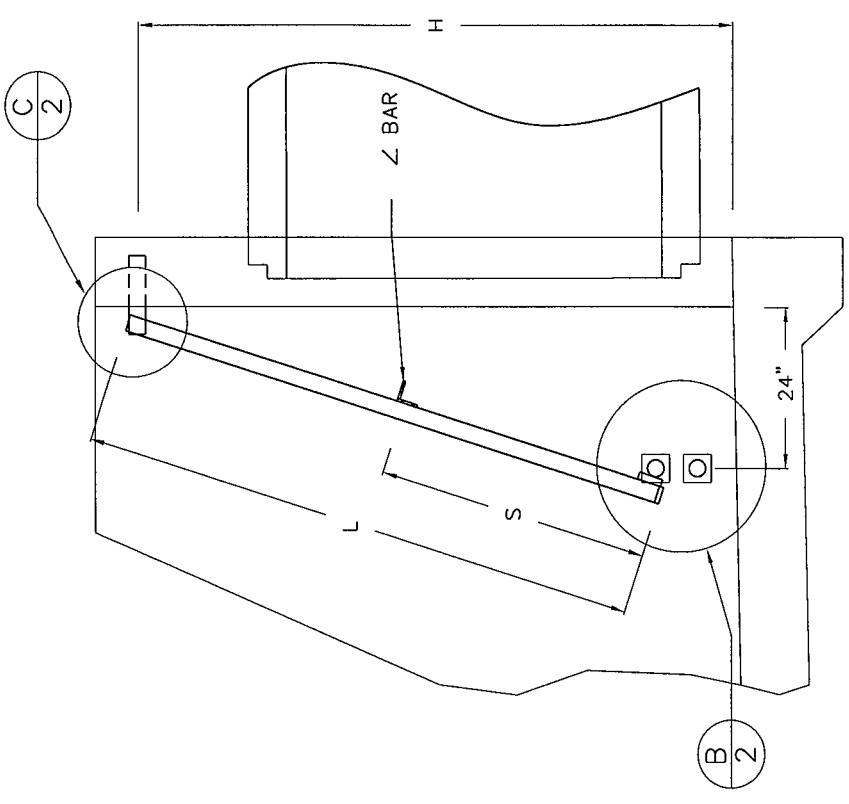

SIDE VIEW

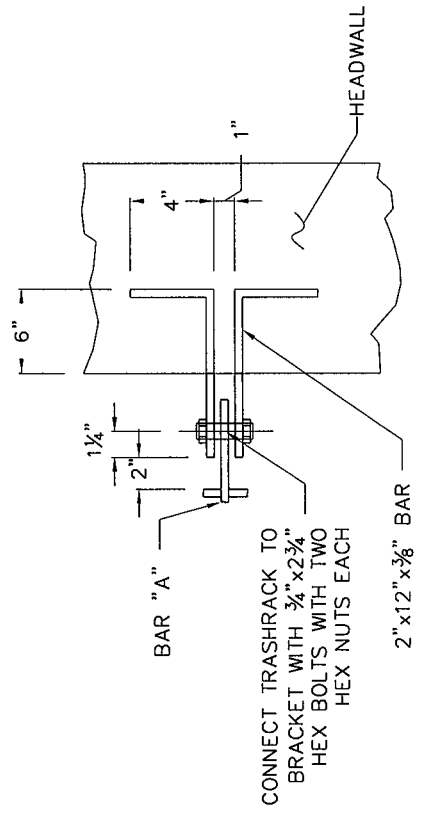

DETAIL A

SIDE BAR LENGTH AND ANGLE WILL BE DETERMINED BY WING WALL DESIGN

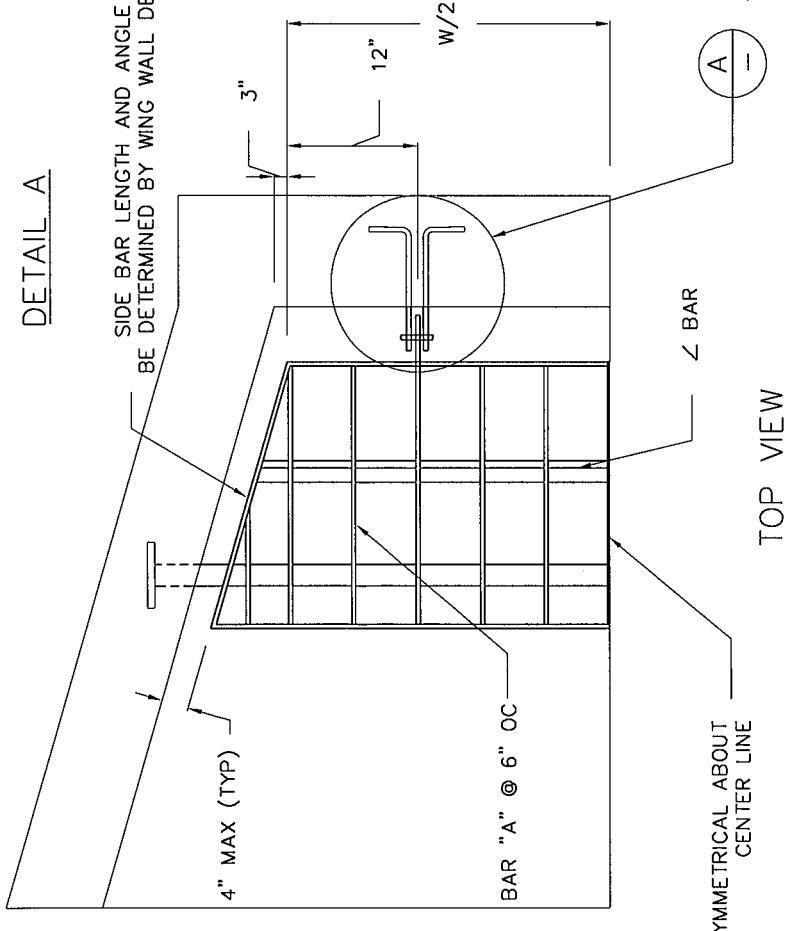

TOP VIEW

SYMMETRICAL ABOUT CENTER LINE

SACRAMENTO COUNTY
MUNICIPAL SERVICES AGENCY

TRASH RACK
24" - 36" PIPE

DRAWN BY: J. ESLABON
SCALE: NONE
REVISION DATE: 10/09

9-26G
SHEET 1 OF 4

Michael L. Peterson

DIRECTOR, DEPARTMENT OF WATER RESOURCES
JANUARY 2014

TRASH RACK DIMENSIONS

PIPE DIA (IN)	PIPE OD (IN)	QUANTITY* BAR "A"	BAR "A" SIZE (IN)	H (IN)	W (IN)	L (IN)	S (IN)
24	30	11	3/8x2 1/2	46	48	40	18
27	33.5	11	3/8x2 1/2	50	48	42	19
30	37	11	3/8x2 1/2	53	48	46	21
33	40.5	11	3/8x2 1/2	57	48	52	24
36	44	13	3/8x2 1/2	60	60	52	24

*Includes outside frame

DRILL 1 3/16" HOLE,
CONNECT TRASH RACK
TO BRACKET WITH 3/4"
BY 2 3/4" HEX BOLTS
WITH TWO HEX NUTS
EACH.

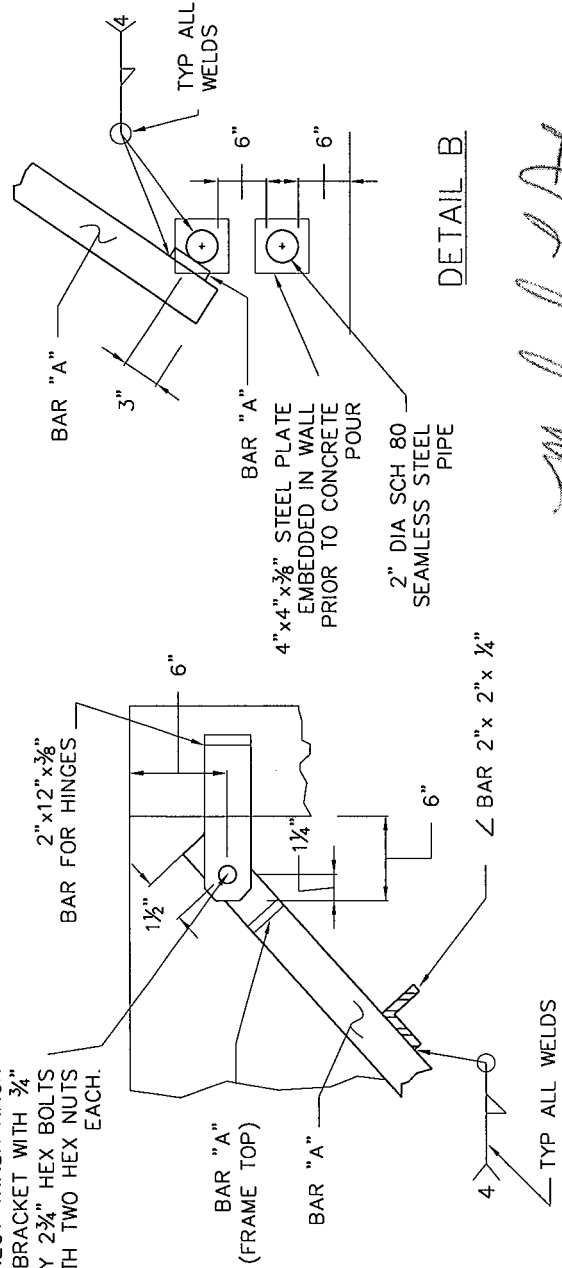

NOTES:

- 1 SEE FIGURE 9-26H FOR PIPE HEADWALL DETAILS.
- 2 MATERIAL TO CONFORM TO ASTM DESIGNATION A-36. GALVANIZE ALL EXPOSED FERROUS PARTS AFTER FABRICATION.
- 3 ALL FILLET WELDS TO BE 3/16".
- 4 ALL STEEL SHALL CONFORM TO SECTION 75 OF THE STATE SPECIFICATIONS AND ASTM A36, A575 AND A576.

SACRAMENTO COUNTY
MUNICIPAL SERVICES AGENCY

TRASH RACK 24" - 36" PIPE

DRAWN BY: J. ESLABON
SCALE: NONE
REVISION DATE: 10/09

9-26G
SHEET 2 OF 4

DIRECTOR, DEPARTMENT OF WATER RESOURCES
JANUARY 2014

Michael L. Peterson

DETAIL C

DETAIL B

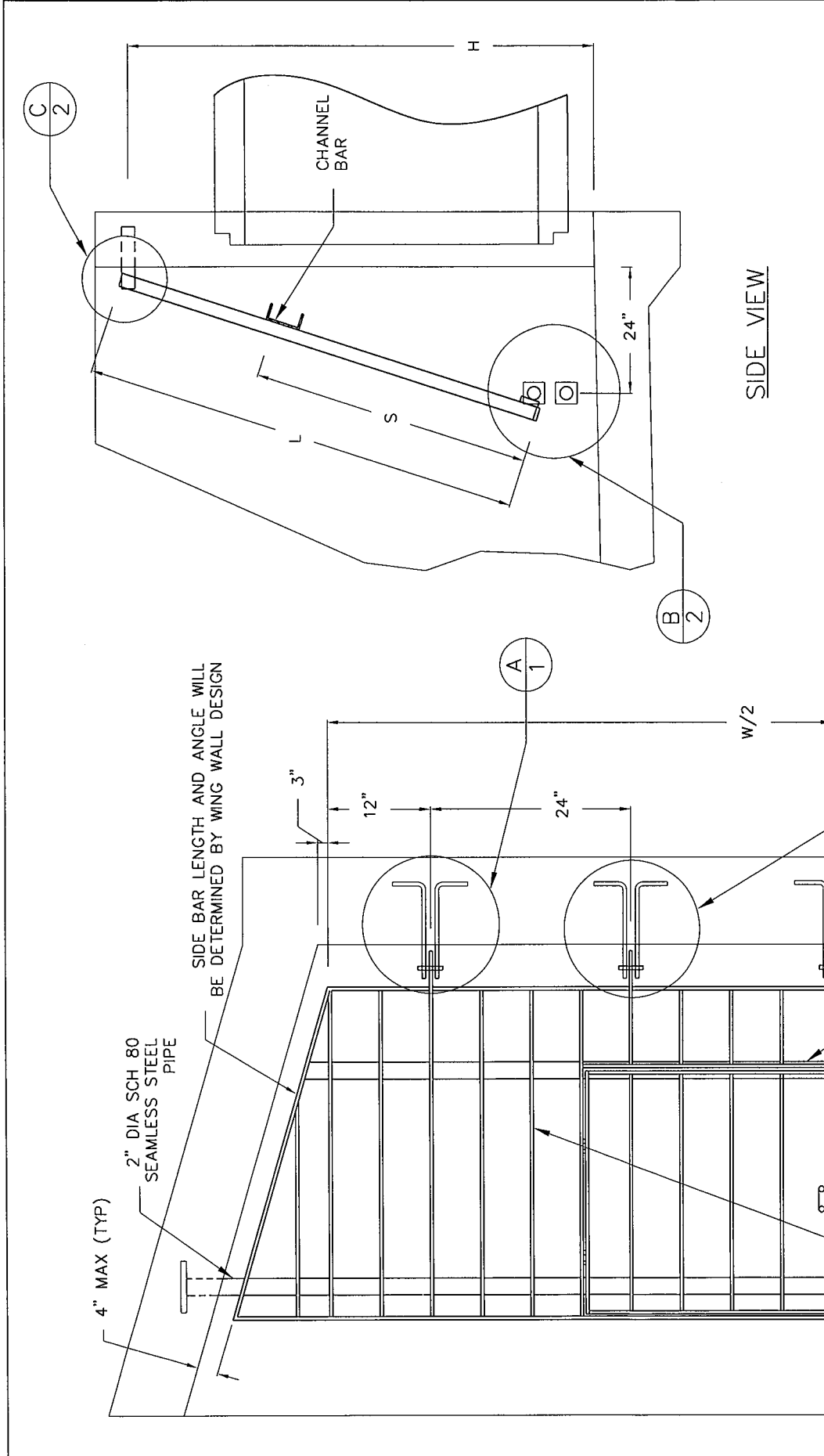

SIDE VIEW

SACRAMENTO COUNTY
 MUNICIPAL SERVICES AGENCY
**TRASH RACK
 42" PIPE AND LARGER**

DRAWN BY: J. ESLABON
 SCALE: NONE
 REVISION DATE: 1/03

9-26G
 SHEET 3 OF 4

SIDE BAR LENGTH AND ANGLE WILL
 BE DETERMINED BY WING WALL DESIGN

ADDITIONAL HINGE REQUIRED
 ON TRASH RACK FOR
 60" AND 72" PIPE

Michael L. Peterson

DIRECTOR, DEPARTMENT OF WATER RESOURCES
 JANUARY 2014

TOP VIEW

4" MAX (TYP)

2" DIA SCH 80
 SEAMLESS STEEL
 PIPE

3"

12"

24"

w/2

3" x 1 1/2" x 1/4" C10
 CHANNEL BAR

ACCESS GATE
 SEE DETAIL
 SHEET 4

BAR "A" @ 6" OC

SYMMETRICAL ABOUT
 CENTER LINE

TRASH RACK DIMENSIONS

PIPE DIA (IN)	PIPE OD (IN)	QUANTITY* BAR "A"	BAR "A" SIZE (IN)	H (IN)	W (IN)	L (IN)	S (IN)
42	51	15	3/8x2-1/2	67	72	60	47-3/4
48	58	17	3/8x2-1/2	74	84	70	47-3/4
54	65	21	3/8x2-1/2	81	108	72	47-3/4
60	72	23	3/8x2-1/2	88	120	80	47-3/4
72	86	27	3/8x2-1/2	102	144	96	47-3/4

*Includes outside frame

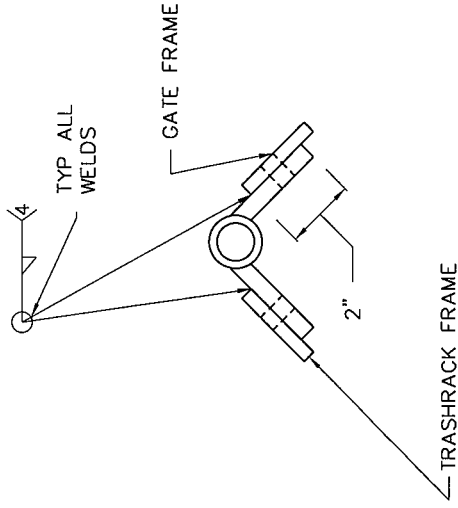
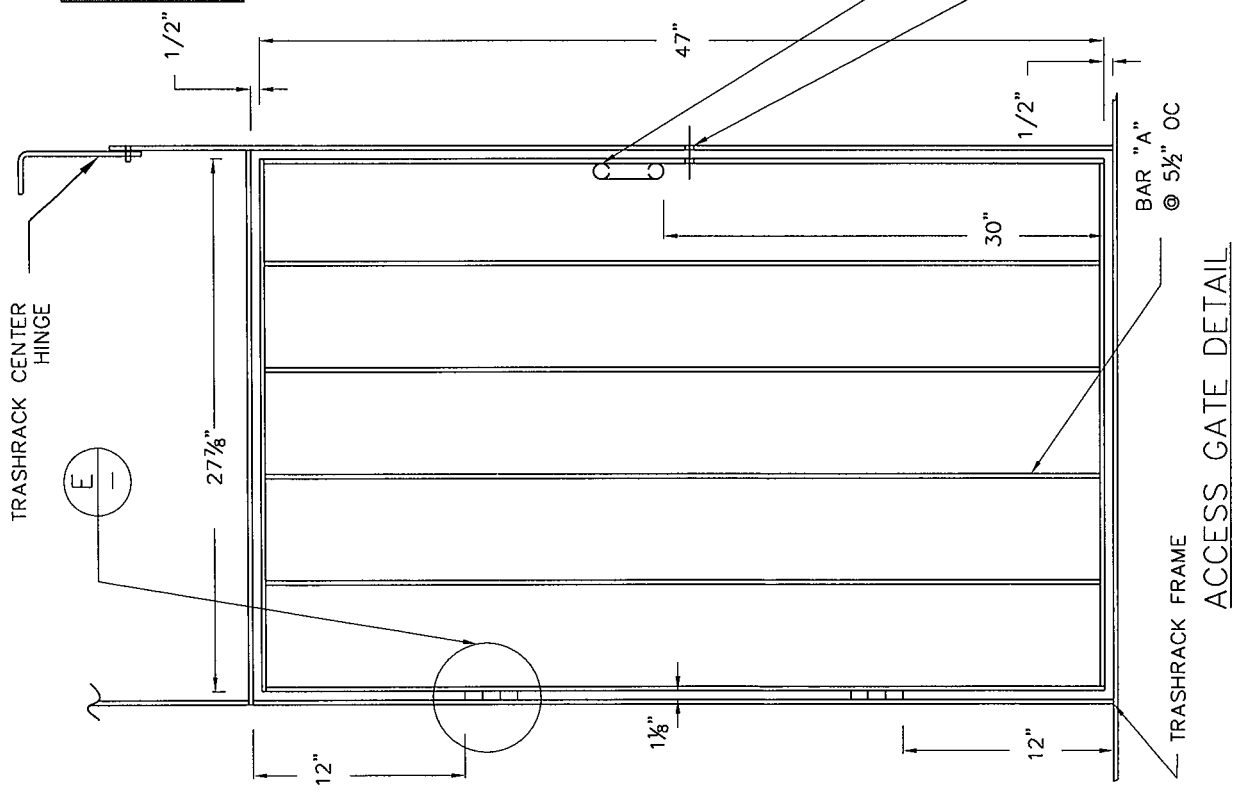

NOTES:

- ① SEE FIGURE 9-26H FOR PIPE HEADWALL DETAILS.
- ② MATERIAL TO CONFORM TO ASTM DESIGNATION A-36. GALVANIZE ALL EXPOSED FERROUS PARTS AFTER FABRICATION.
- ③ ALL FILLET WELDS TO BE 3/16".
- ④ ALL STEEL SHALL CONFORM TO SECTION 75 OF THE STATE SPECIFICATIONS AND ASTM A36, A575 AND A576.
- ⑤ GATE HINGES TO BE COATED TO RESIST CORROSION.

SACRAMENTO COUNTY
MUNICIPAL SERVICES AGENCY

**TRASH RACK
42" PIPE AND LARGER**

DRAWN BY: J. ESLABON
SCALE: NONE
REVISION DATE: 1/03

9-26G
SHEET 4 OF 4

Michael L. Peterson
DIRECTOR, DEPARTMENT OF WATER RESOURCES
JANUARY 2014

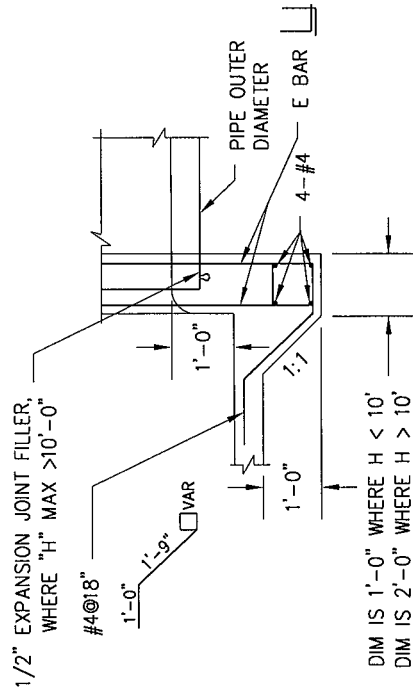
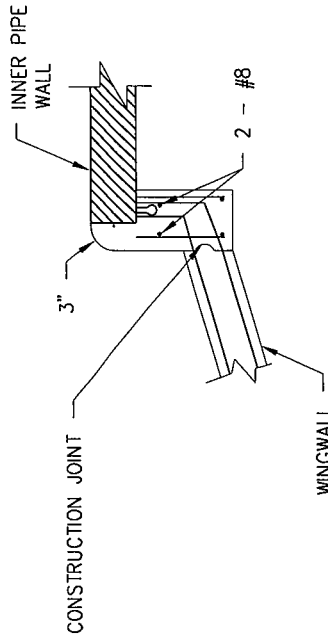

DIM IS 1'-0" WHERE H < 10'
 DIM IS 2'-0" WHERE H > 10'

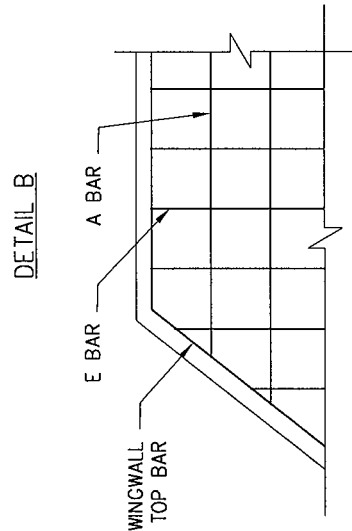

NOTES

- ① PLACE #5 REBAR ON DIAGONALS @ 4" FROM PIPE OD.
- ② PIPE CONNECTIONS SHALL CONFORM TO ASTM C-923. UNITS SHALL INCLUDE A WATER STOP.
- ③ CHAMFER ALL EXPOSED EDGES 3/4".
- ④ ALL STEEL MINIMUM 2" FROM CONCRETE EDGES.
- ⑤ ALL LAP SPLICES MINIMUM 12".

HEADWALL DIMENSIONS

PIPE DIA	PIPE OD	W	H _{min}	T*	L _{min}
24"	31.5"	4'-6"	4'-10"	10"	2'-9"
27"	35"	4'-6"	5'-1"	10"	3'-0"
30"	38.5"	4'-6"	5'-5"	10"	3'-3"
33"	42"	4'-6"	5'-8"	10"	3'-6"
36"	45.5"	5'-6"	5'-11"	10"	3'-9"
42"	52.5"	6'-6"	6'-6"	10"	4'-3"
48"	59.5"	7'-6"	7'-0"	10"	5'-3"
54"	66.5"	9'-6"	7'-7"	10"	5'-9"
60"	73.5"	10'-6"	8'-1"	10"	6'-0"
72"	87.5"	12'-6"	9'-2"	10"	7'-3"

REINFORCING STEEL DIMENSIONS AND DATA

	A BAR	B BAR	C BAR	D BAR	E BAR	WINGWALL TOP BAR
H ≤ 7'	#4@12"OC	#4@12"OC	#4@12"OC	#4@12"OC	#4@12"OC	#4
7' < H ≤ 8'	#4@12"OC EF	#4@12"OC EF	#4@12"OC EF	#4@12"OC EF	#4@12"OC EF	#4
8' < H ≤ 10'	#5@12"OC EF	#5@6"OC EF	#5@12"OC EF	#5@12"OC EF	#5@12"OC EF	#5

SACRAMENTO COUNTY
 MUNICIPAL SERVICES AGENCY

PIPE HEADWALL, ENDWALL
 WINGWALL STRUCTURE

Michael L. Peterson

DIRECTOR, DEPARTMENT OF WATER RESOURCES
 JANUARY 2014

DRAWN BY: STAFF
 SCALE: NONE
 REVISION DATE: 10/08

9-26H
 SHEET 2 OF 3

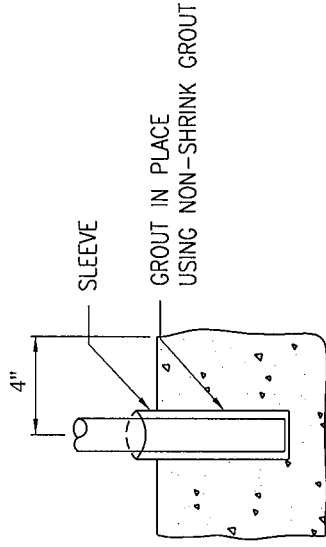
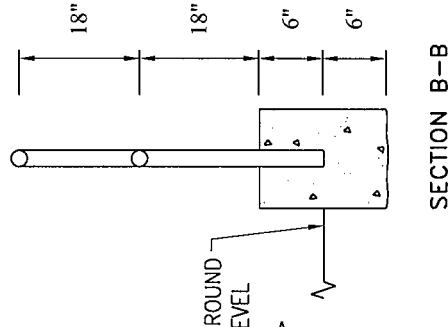
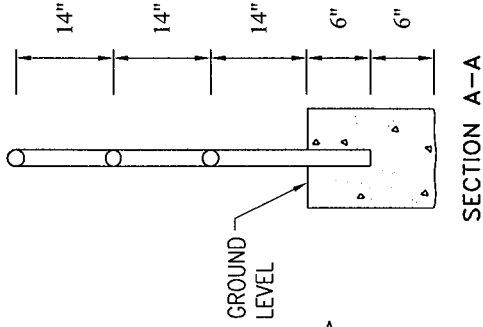
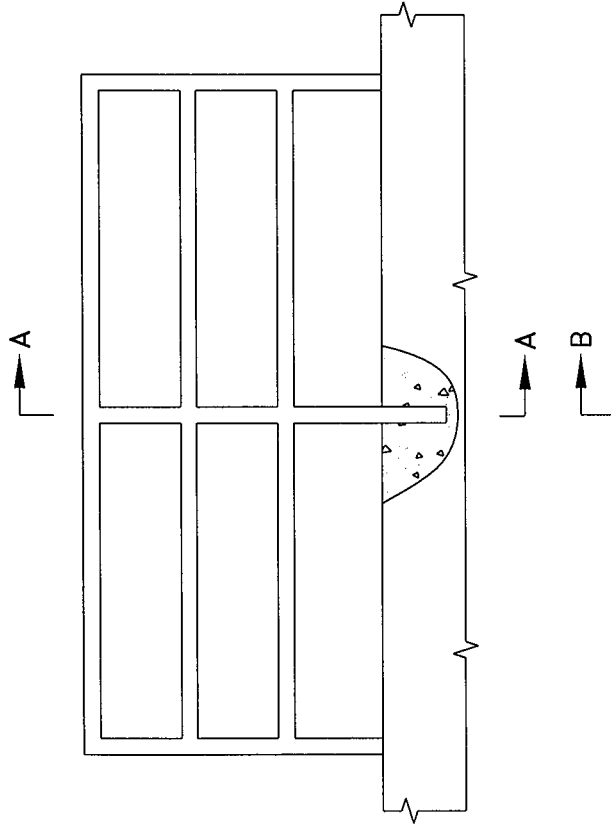

GENERAL NOTES:

1. GUARDRAIL - 1 1/2" SEAMLESS STEEL PIPE ASTM 53 GRADE B, HOT DIP GALVANIZED. PAINT COLOR (IF NEEDED) TO BE SPECIFIED ON PLANS AT NO EXTRA COST.
2. ALL GUARDRAIL WELDS 3/16" FILLET GROUND SMOOTH.
3. MAXIMUM SPACING OF POSTS SHALL BE 6'.
4. TO BE SHOWN ON IMPROVEMENT PLANS FOR PLACEMENT.

SECTION B-B

SECTION A-A

SACRAMENTO COUNTY
MUNICIPAL SERVICES AGENCY

**PIPE HEADWALL, ENDWALL
WINGWALL STRUCTURE**

DRAWN BY: S. PIMENTEL
SCALE: NONE
REVISION DATE: 10/09

DIRECTOR, DEPARTMENT OF WATER RESOURCES
JANUARY 2014

Michael L. Peterson

9-26H

SHEET 3 OF 3

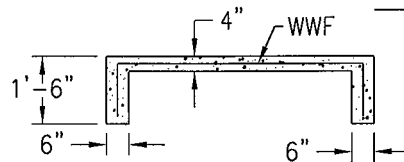
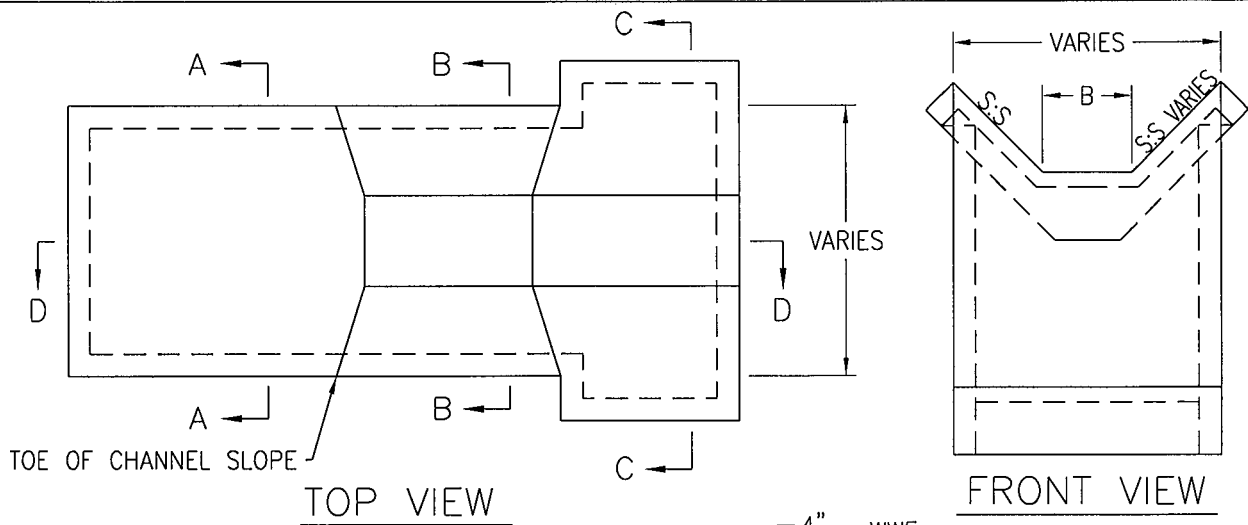

SECTION A-A

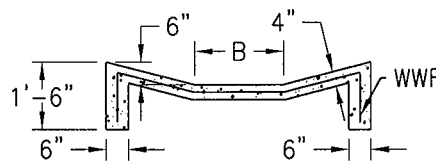

SECTION B-B

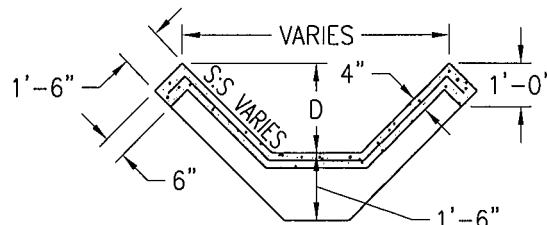

SECTION C-C

NOTES

1. USE CLASS "B" CONCRETE OR GROUTED COBBLES AS SPECIFIED.
2. 4"x4"-W4XW4 WWF THROUGHOUT CONCRETE
3. ON LINED CHANNELS APRON SHALL CONNECT TO SIDE LINING.
4. B=DITCH BOTTOM WIDTH OR AS SHOWN ON PLANS.
5. D=DITCH WATER DEPTH PLUS ONE FOOT OF FREEBOARD.

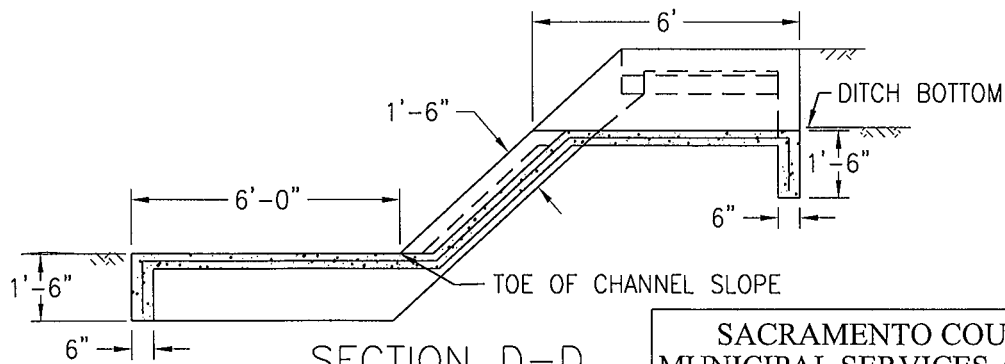

SECTION D-D

SACRAMENTO COUNTY
MUNICIPAL SERVICES AGENCY

**EROSION CONTROL
DITCH DISCHARGE**

DRAWN BY: M.FIELDS
SCALE: NONE
REVISION DATE: 10/09

9-27

Michael L. Peterson

DIRECTOR, DEPARTMENT OF WATER RESOURCES
JANUARY 2014

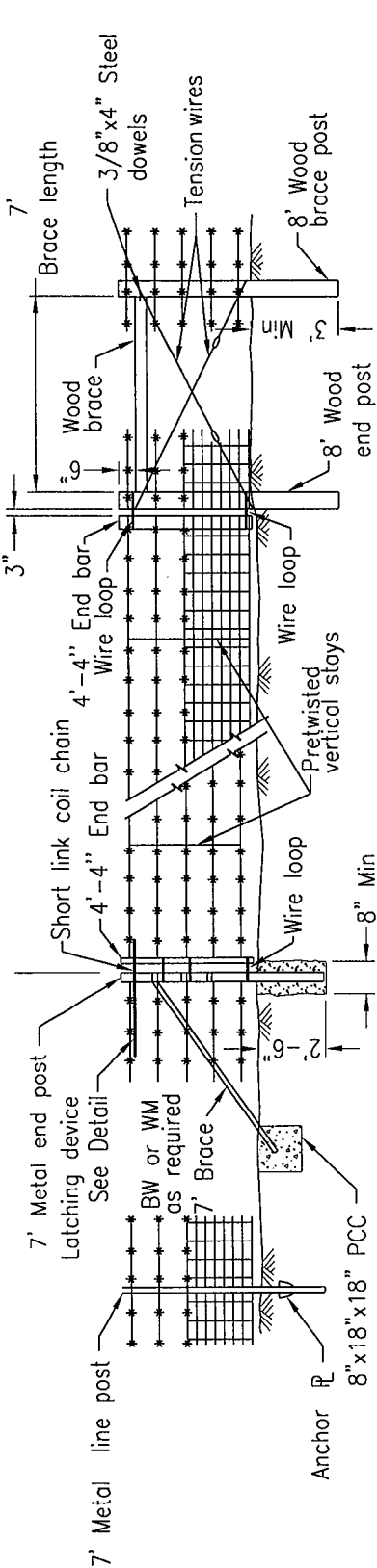

METAL POST INSTALLATION

WOOD POST INSTALLATION

GATEWAY
See Note 3

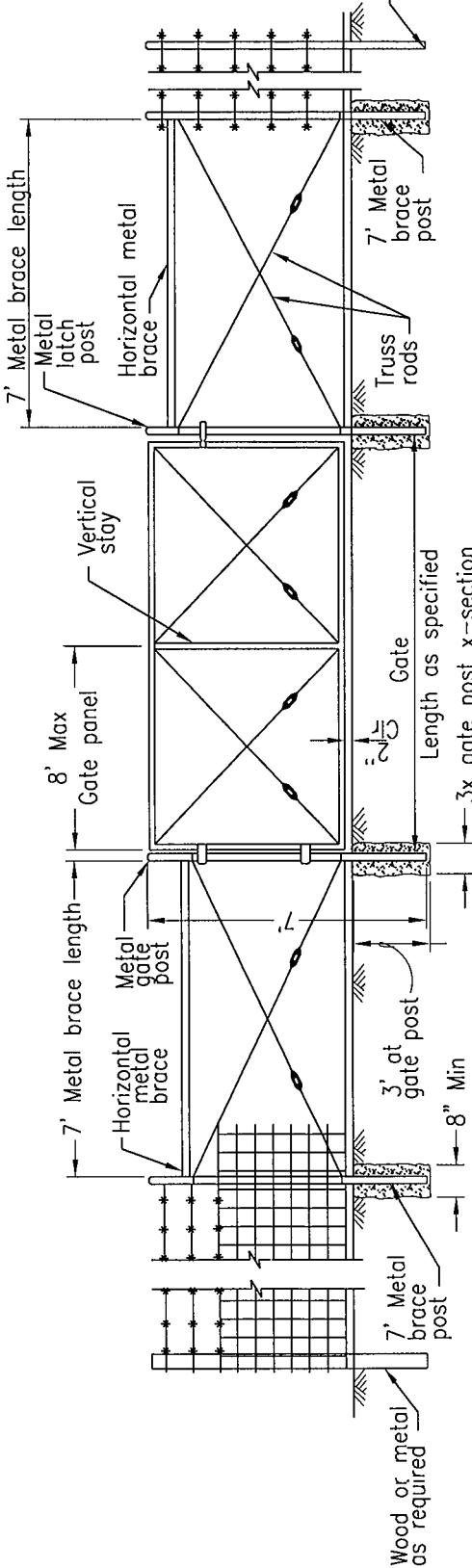

**WIRE MESH GATE INSTALLATION FOR
EITHER WOOD OR METAL POST FENCES**

SACRAMENTO COUNTY
MUNICIPAL SERVICES AGENCY

**BARBED WIRE AND
WIRE MESH FENCES**

Michael L. Peterson

DIRECTOR, DEPARTMENT OF WATER RESOURCES
JANUARY 2014

9-28
SHEET 1 OF 3

DRAWN BY: STAFF
SCALE: NONE
REVISION DATE: 11/98

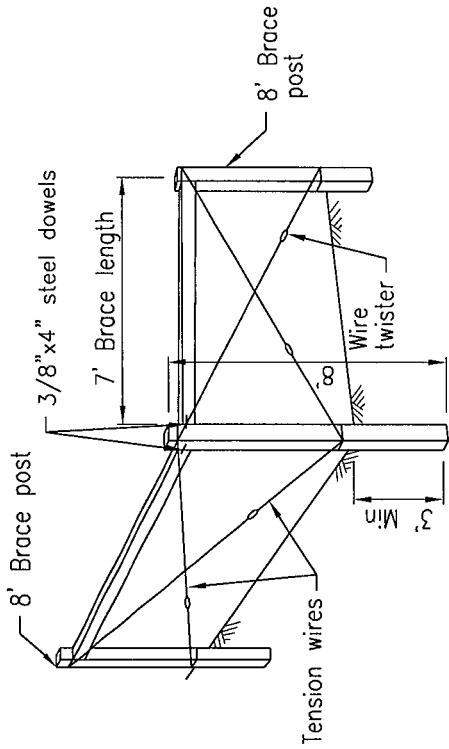

END AND CORNER POST ASSEMBLY

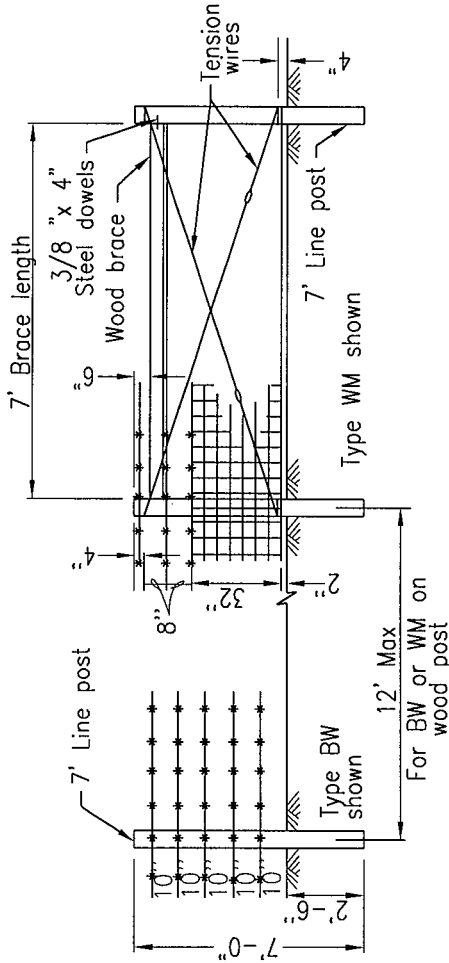

PULL POST ASSEMBLY

Type BW = 5 lines of barbed wire.
 Type WM = Wire mesh and 3 lines of barbed wire.

At 660' maximum intervals for WM fence.
 At 1320' maximum intervals for BW fence.

WOOD POST INSTALLATION

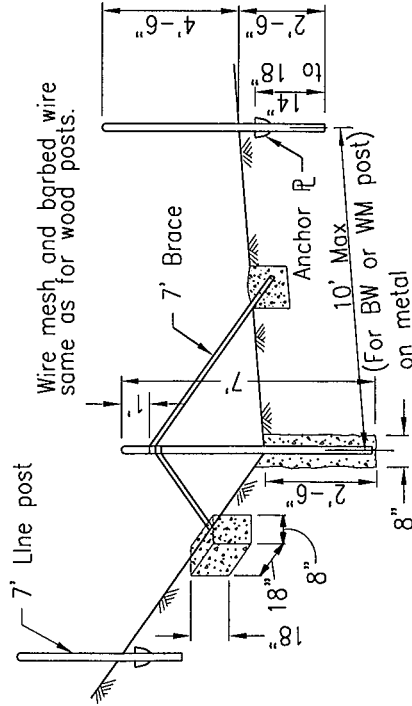

END AND CORNER POST ASSEMBLY

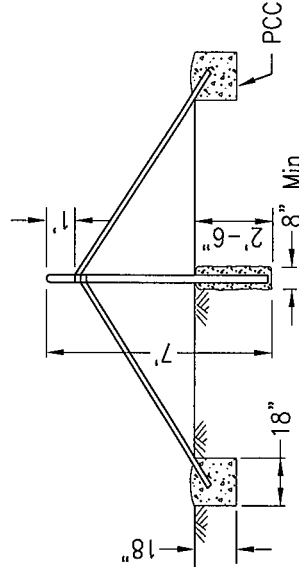

PULL POST ASSEMBLY

At 660' maximum intervals for WM fence.
 At 1320' maximum intervals for BW fence.

METAL POST INSTALLATION

SACRAMENTO COUNTY
 MUNICIPAL SERVICES AGENCY

**BARBED WIRE AND
 WIRE MESH FENCES**

DRAWN BY: STAFF
 SCALE: NONE
 REVISION DATE: 11/98

9-28
 SHEET 2 OF 3

DIRECTOR, DEPARTMENT OF WATER RESOURCES
 JANUARY 2014

Michael L. Peterson

WIRE MESH GATE POST (See Note 4)		
GATE WIDTHS	NOMINAL OD	WEIGHT PER FT
Up thru 6'	2-7/8"	5.79
Over 6' thru 12'	4"	9.11
Over 12' thru 18'	5 -9/16"	14.62
Over 18' to 24' Max	6-5/8"	18.97

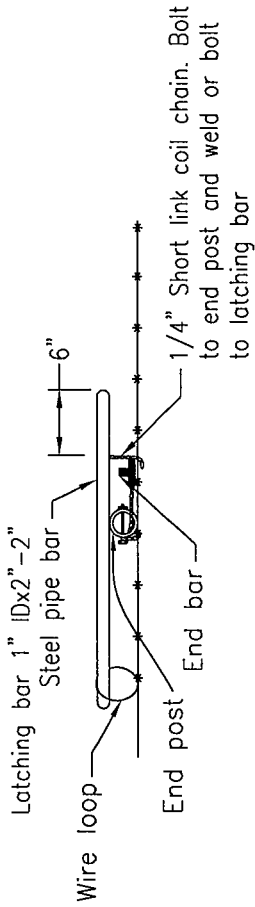

LATCHING DEVICE FOR GATEWAYS

See Note 1

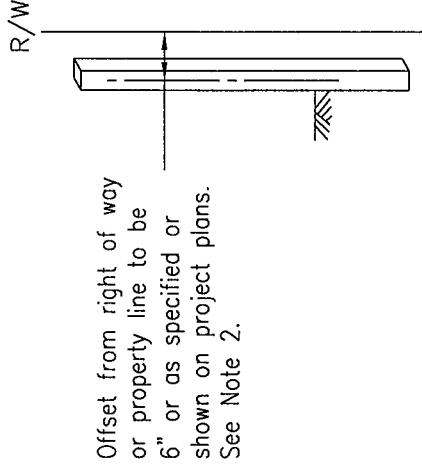

FENCE LOCATION

NOTES:

1. Metal end post and end bar shown. Use wood end post and end bar for wood post installation.
2. Offset to be 2' at monument locations, measured at right angles to R/W lines. Taper to achieve offset to be at least 20' long.
3. Gateway to be used when specified in the special provisions.
4. Post dimensions and weights are minimums. Larger sizes may be used on approval of Engineer.
5. Line post spacing for wood post equals 12' maximum. Line post spacing for metal post equals 10' maximum.

SACRAMENTO COUNTY
MUNICIPAL SERVICES AGENCY

**BARBED WIRE AND
WIRE MESH FENCES**

DRAWN BY: STAFF
SCALE: NONE
REVISION DATE: 4/07

DIRECTOR, DEPARTMENT OF WATER RESOURCES
JANUARY 2014

9-28
SHEET 3 OF 3

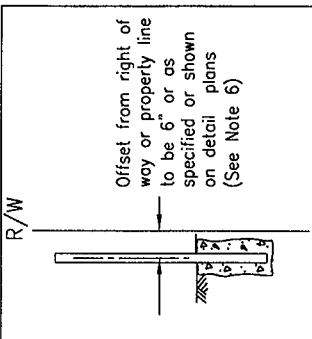

FENCE LOCATION

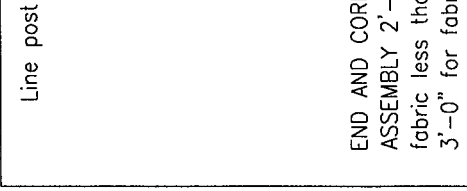
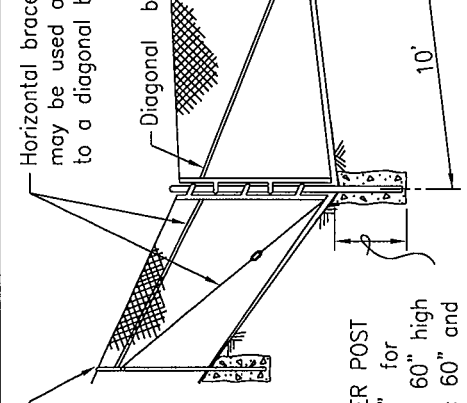
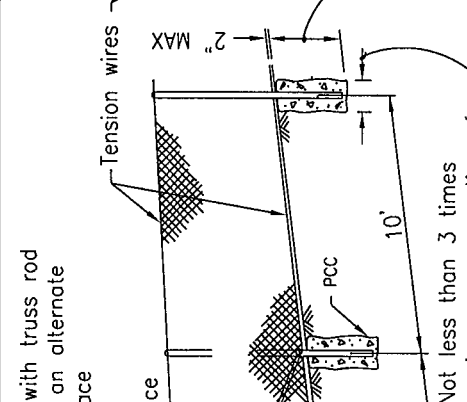
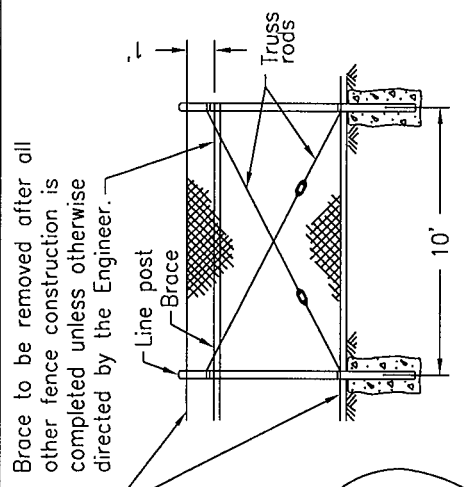

Line posts at 1000' maximum intervals braced and trussed in both directions except that this bracing and trussing may be omitted when the fabric is stretched by the equipment

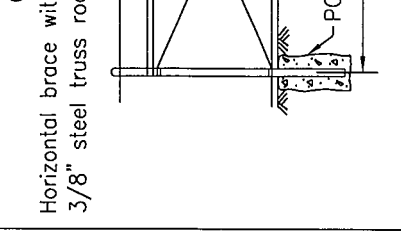
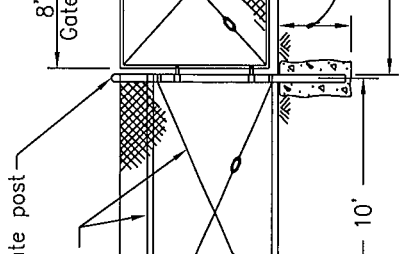
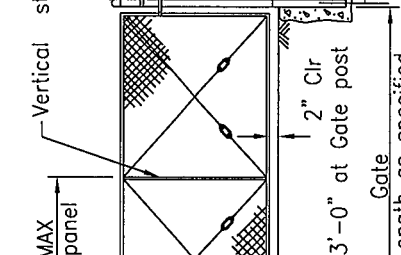
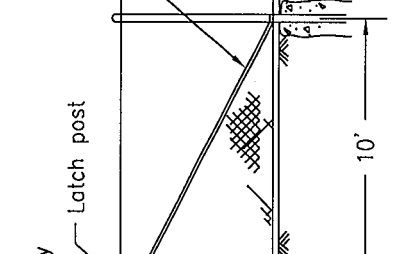
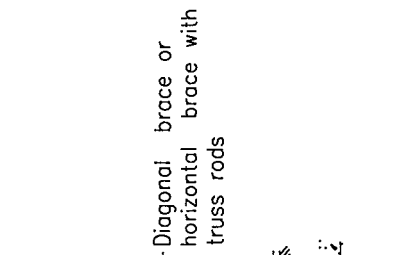

Type CL-4=48" fabric
Type CL-6=72" fabric

- Notes:
1. Chain link fabric shall be zinc coated steel manufactured in compliance with ASTM Standard A 392 with a 2 inch mesh of 9 gauge wire with knuckled selvage.
 2. Tension wire shall be 7 gauge.
 3. Where barbed wire is specified, it shall include 3 strands of galvanized 4 point wire attached with extension arms set at 45 degrees.

SACRAMENTO COUNTY
MUNICIPAL SERVICES AGENCY

CHAIN LINK FENCE

DRAWN BY: STAFF
SCALE: NONE
REVISION DATE: 12/99

DIRECTOR, DEPARTMENT OF WATER RESOURCES
JANUARY 2014

Michael L. Peterson

9-29
SHEET 1 OF 2

(See Notes)

TYPICAL MEMBER DIMENSIONS

FENCE HEIGHT	LINE POSTS		END, LATCH & CORNER POSTS		RAILS & BRACES	
	NOMINAL ROUND O.D. (NOTES 7 & 8)	H	ROLL FORMED	NOMINAL ROUND O.D. (NOTES 7 & 8)	H	ROLL FORMED
6' & less	2-3/8"	1-7/8" x 1-5/8"	3-1/2" x 3-1/2"	2-7/8"	1-1/2" x 1-5/16"	1-5/8" x 1-1/4"
Over 6'	2-3/8"	2-1/4" x 2"	3-1/2" x 3-1/2"	2-7/8"	1-1/2" x 1-5/16"	1-5/8" x 1-1/4"

GATE POST (NOTE 7)		WEIGHT PER FOOT
FENCE HEIGHT	GATE WIDTHS	
6'-0" and Less	Up thru 6'	5.79
	Over 6' thru 12'	10.79
	Over 12' thru 18'	14.62
	Over 18' to 24' max	18.97
Over 6'-0"	Up thru 6'	7.58
	Over 6' thru 12'	14.62
	Over 12' thru 18'	18.97
	Over 18' to 24' max	28.55

NOTES

- The above table shows examples of post and brace sections which may comply with the Standard Construction Specifications.
- Sections shown in the tables must also comply with the strength requirements and other provisions of the Standard Construction Specifications.
- Other sections which comply with the strength requirements and other provisions of the Standard Construction Specifications may be used on approval of the Engineer.
- Options exercised shall be uniform on any one project.
- Dimensions shown are nominal.
- Offset to be 2'-0" at monument locations, measured at right angles to R/W lines. Taper to achieve offset to be at least 20' long.
- Pipe sections for posts, rails, braces, and gates shall be schedule 40 galvanized pipe manufactured in conformance with ASTM F 1083.
- Weight per foot values for 1-5/8" O.D. pipe = 2.27 lbs/ft, 2-3/8" O.D. pipe = 3.65 lbs/ft, 2-7/8" O.D. pipe = 5.79 lbs/ft.
- Chain link gate frames shall be a minimum of 1-7/8" pipe weighing 2.72 lbs/ft.
- Galvanized gate holders of heavy cost construction with counterbalanced latches shall be provided for all gates. Gate holders shall be anchored with a minimum 24" length of 1-5/8" schedule 40 pipe set in 8" ϕ concrete base.
- Double gate assemblies shall also be fitted with heavy duty hinges and lift bar interlocking device with drop anchor at midspan that latches to embedded pipe.

Above post dimensions and masses are minimums. Larger sizes may be used on approval of the Engineer.



DIRECTOR, DEPARTMENT OF WATER RESOURCES
JANUARY 2014

SACRAMENTO COUNTY
MUNICIPAL SERVICES AGENCY

CHAIN LINK FENCE

DRAWN BY: STAFF
SCALE: NONE
REVISION DATE: 2/07

9-29
SHEET 2 OF 2

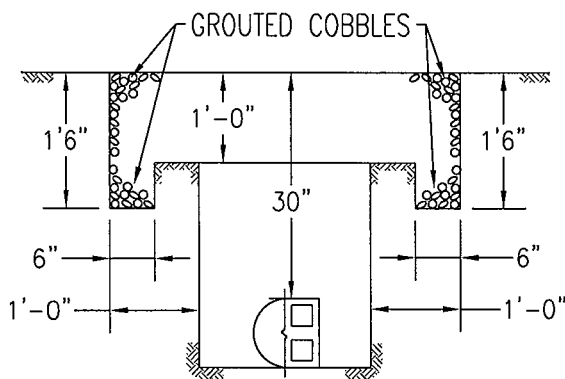
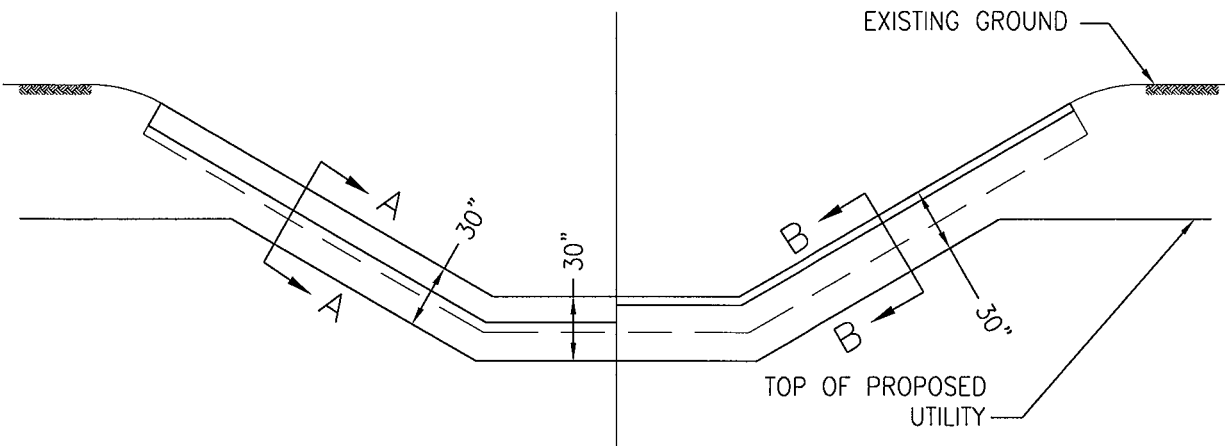

SECTION A-A

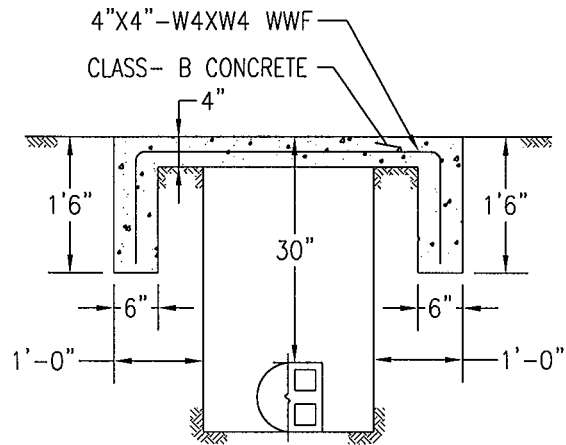

SECTION B-B

NOTES

1. ALL UTILITY CROSSINGS OF EXISTING STREAMS SHALL BE AT LEAST 30" BELOW EXISTING CHANNEL SIDES AND BOTTOMS. DEEPER PLACEMENT MAY BE REQUIRED IF FUTURE CHANNEL IMPROVEMENTS ARE ANTICIPATED.
2. THE CUT SHALL BE SEALED AS SHOWN WITH GROUDED COBBLES OR CLASS B CONCRETE TO A WIDTH OF 1' ON EACH SIDE OF THE UTILITY TRENCH. ALL NATURAL STREAMS, AS SHOWN ON THE NATURAL STREAMS PLAN, SHALL UTILIZE GROUDED COBBLES.
3. CONSTRUCTION IS TO CONFORM TO SECTION 44 OF THE COUNTY CONSTRUCTION SPECIFICATIONS WITH CUT OFF WALLS CONFORMING TO STANDARD DRAWING 9-24.

Michael L. Peterson

DIRECTOR, DEPARTMENT OF WATER RESOURCES
JANUARY 2014

SACRAMENTO COUNTY
MUNICIPAL SERVICES AGENCY

UTILITY STREAM CROSSING

DRAWN BY: M.FIELDS
SCALE: NONE
REVISION DATE: 10/09

9-30

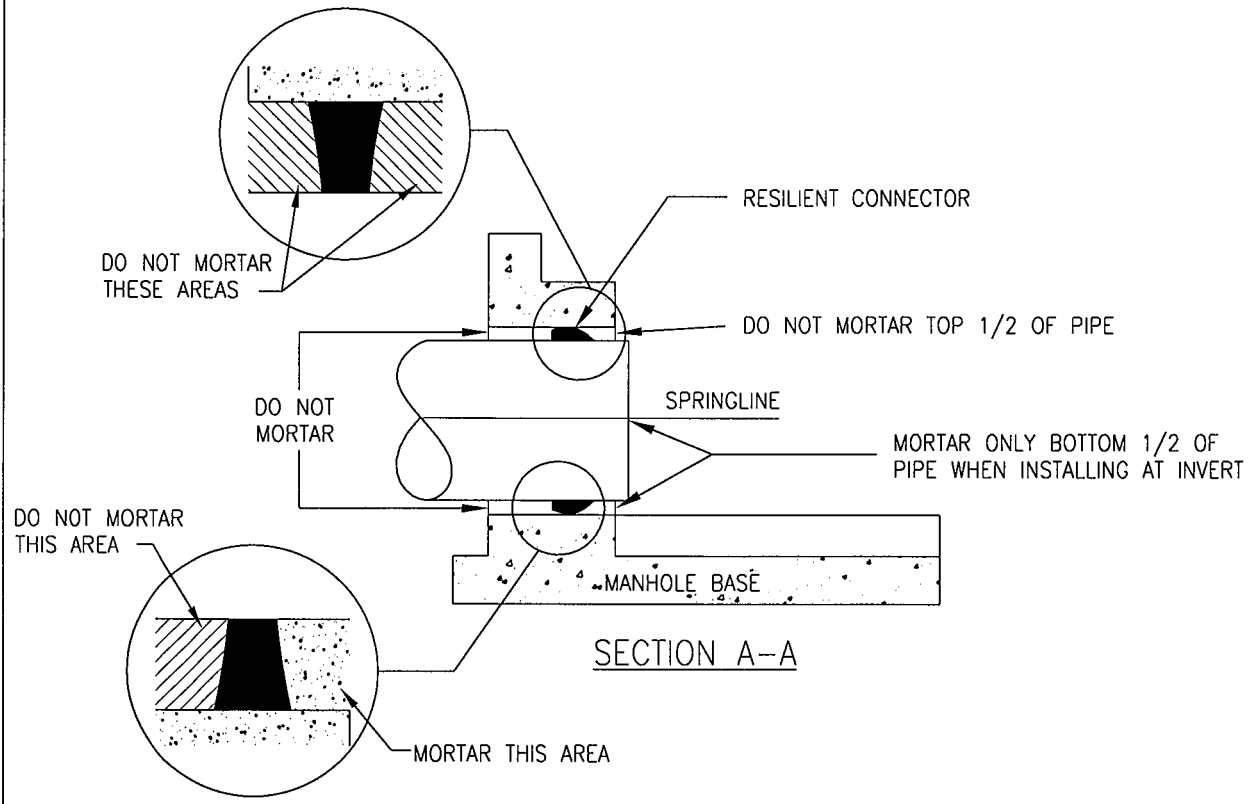

SECTION A-A

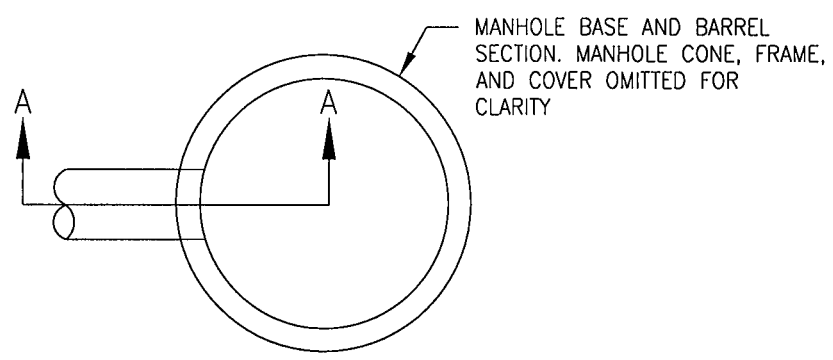

PLAN

NOTES:

1. TO HELP CREATE A FLEXIBLE, WATERTIGHT JOINT, DO NOT PLACE MORTAR AROUND THE CONNECTOR ON THE OUTSIDE OF THE STRUCTURE. ALSO, DO NOT PLACE MORTAR AROUND THE TOP HALF OF THE CONNECTOR ON THE INSIDE WHEN COMPLETING THE INVERT WORK.
2. RESILIENT CONNECTORS SHALL BE A FLEXIBLE COMPRESSION GASKET OR BOOT CONNECTOR PER SECTION 39 "MANHOLES" OF THE COUNTY CONSTRUCTION SPECIFICATIONS.
3. BOOT CONNECTORS SHALL NOT BE GROUTED.
4. ALL CONNECTORS SHALL MEET OR EXCEED THE REQUIREMENTS OF ASTM C-923

Michael L. Peterson
 DIRECTOR, DEPARTMENT OF WATER RESOURCES
 JANUARY 2014

SACRAMENTO COUNTY MUNICIPAL SERVICES AGENCY	
FLEXIBLE CONNECTOR PIPE TO MANHOLE	
DRAWN BY: STAFF SCALE: NONE REVISION DATE: 10/09	9-31

CONSTRUCTION NOTES

1. Fabricate and install in conformance with Section 12-3.06A of the State Standard Specifications.
2. Sign panel shall conform to Type IIIA minimum reflective sheeting requirements of Section 12-3.06A of the State Standard Specifications.
3. Sign panel colors shall be black letters and border on a white background. Letter height and weight as follows:

Letter Height	Line Weight
1-1/2"	5/16"
2"	1/4"
3"	3/8"
4. The County Seal emblem shall be provided by the County and installed as shown by the Contractor.
5. 4x4 Wood post shall be installed in conformance with Section 12-3.06A of the State Standard Specifications.

Michael L. Peterson

DIRECTOR, DEPARTMENT OF WATER RESOURCES
JANUARY 2014

SACRAMENTO COUNTY MUNICIPAL SERVICES AGENCY	
CONSTRUCTION SITE SIGN	
SCALE: NONE REVISION DATE: 2/07 DRAWN BY: S.R.P.	9-32

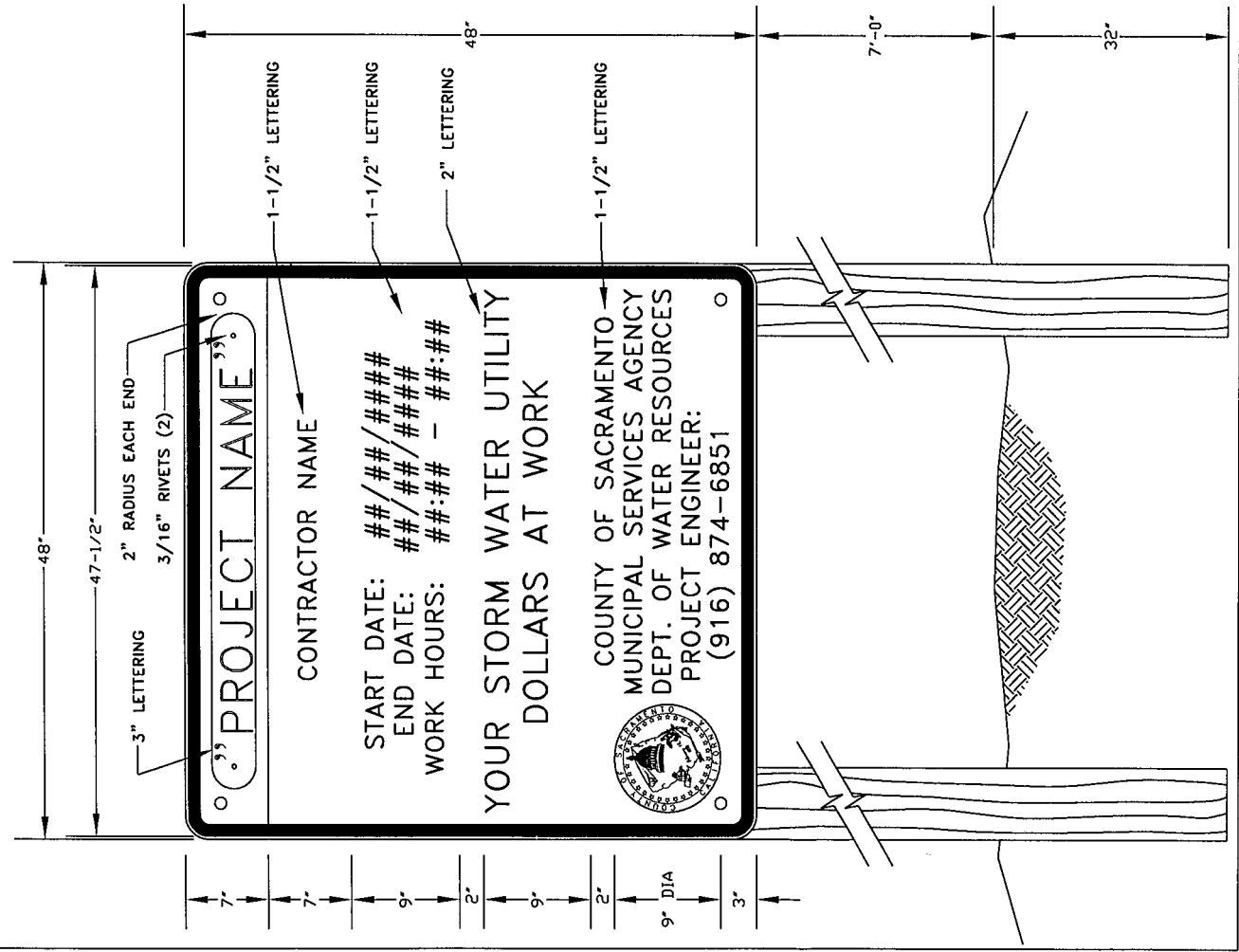

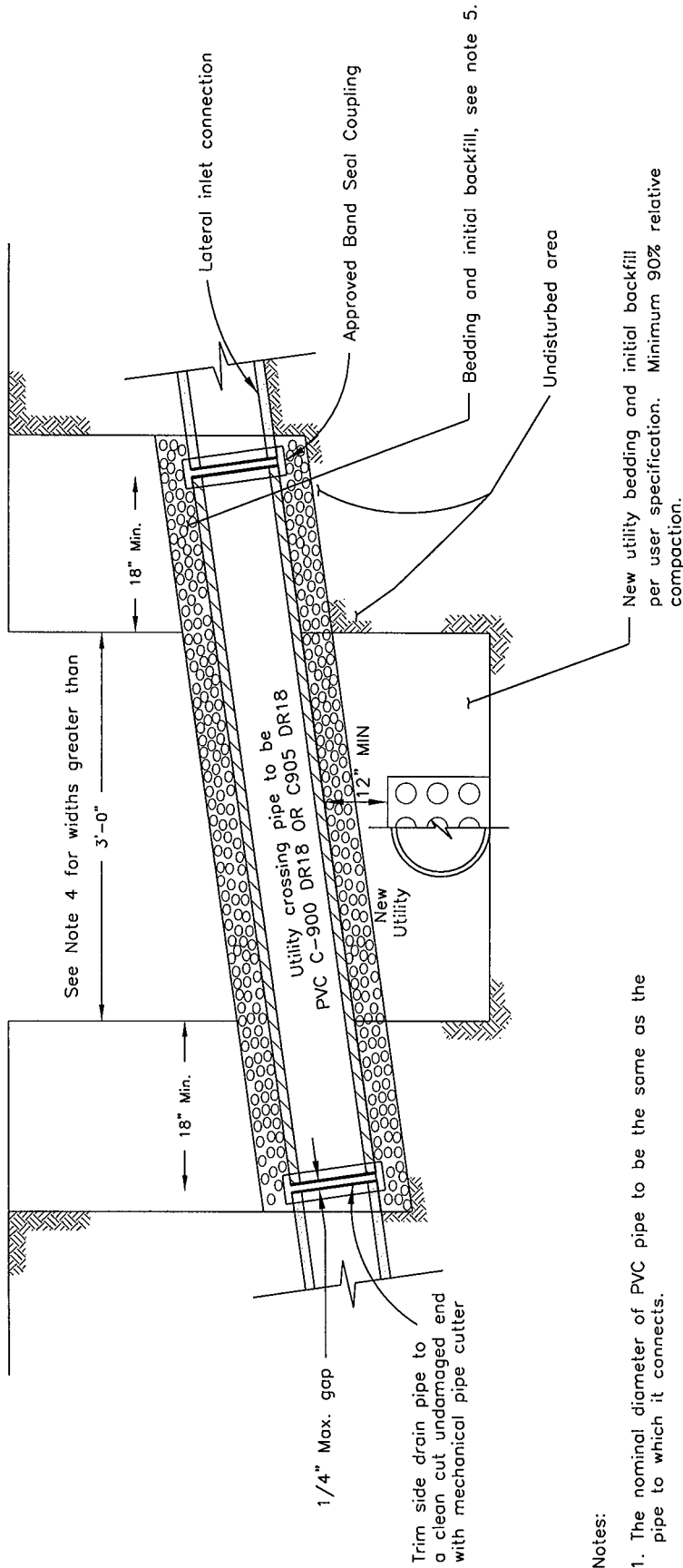

Notes:

1. The nominal diameter of PVC pipe to be the same as the pipe to which it connects.
2. Use PVC pipe when the lateral connection is cut or damaged.
3. Alteration of pipe grades will be permitted only after written permission has been received from the engineer.
4. Whenever the span, whether caused by trench width or crossing angle of the PVC pipe, exceeds 3'-0". Replacement procedure and material shall be as directed by the engineer.
5. Bedding and initial backfill material shall be imported 3/4-inch crushed rock or gravel conforming to the requirements of Article 50-16, Type "B". For pipe 10" or less in diameter use 1/2-inch crushed rock or gravel conforming to Article 50-16, Type "A". Place per Standard Drawing 9-1A.
6. PVC pipe shall conform to section 50-26.04, "Polyvinyl Chloride Pipe (PVC) For Drainage", of the Standard Specifications.

See Note 4 for widths greater than 3'-0"

18" Min.

18" Min.

1/4" Max. gap

Trim side drain pipe to a clean cut undamaged end with mechanical pipe cutter

Lateral inlet connection

Approved Band Seal Coupling

Bedding and initial backfill, see note 5.

Undisturbed area

New utility bedding and initial backfill per user specification. Minimum 90% relative compaction.

Utility crossing pipe to be PVC C-900 DR18 OR C905 DR18

New Utility

1 1/2" MIN

SACRAMENTO COUNTY
MUNICIPAL SERVICES AGENCY

UTILITY CROSSING

DRAWN BY: STAFF
SCALE: NONE
REVISION DATE: 4/97

9-33

Michael L. Petersen

DIRECTOR, DEPARTMENT OF WATER RESOURCES
JANUARY 2014

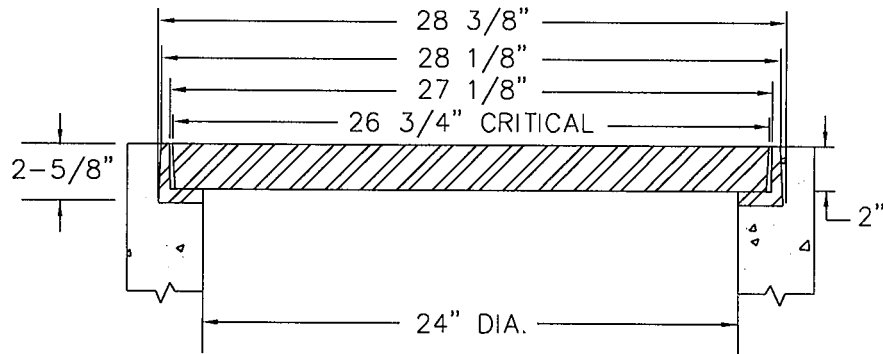
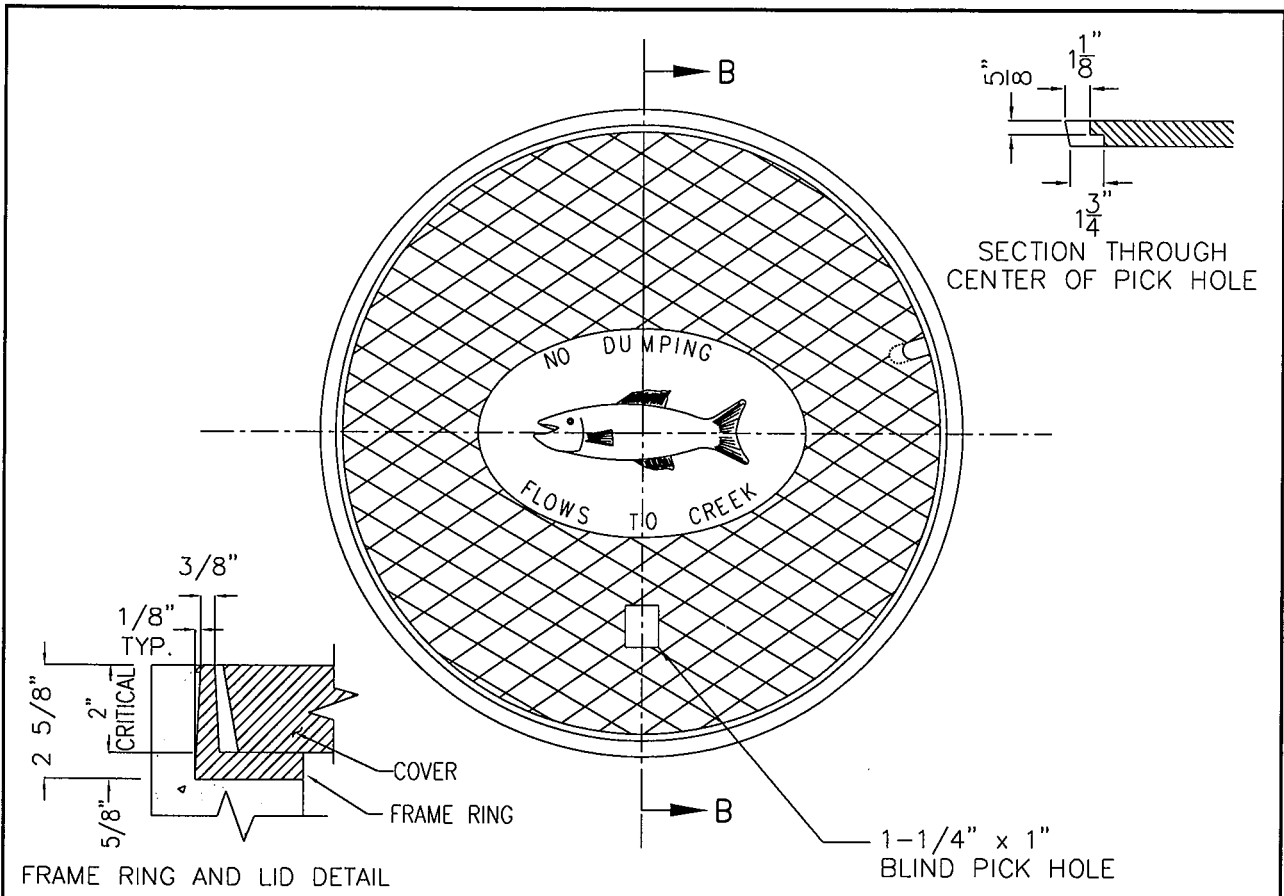

SECTION B-B

NOTES:

1. TO BE USED ONLY WITH TYPE G OR 300-1 INLET.
2. ALL CASTINGS TO CONFORM TO ASTM A48, CLASS 35B.
3. FRAME AND COVER TO MEET H-20 LOAD SPECIFICATIONS.
4. BEARING SURFACES ARE MACHINED BEVELED TO ASSURE A CLOSE, NON ROCKING SURFACE.
5. EXPOSED SURFACES OF THE CASTINGS WITH THE PARTS ASSEMBLED AND DISASSEMBLED SHALL BE PAINTED WITH COMMERCIAL QUALITY ASPHALTUM PAINT AFTER TESTING AND ASSEMBLY.
6. SEE ARTICLE 50-34, "SEWER AND STORM DRAIN CASTINGS", OF SECTION 50.

WEIGHT	
CAST IRON COVER	91 LBS.
CAST IRON FRAME RING	52 LBS.

Michael L. Peterson

DIRECTOR, DEPARTMENT OF WATER RESOURCES
JANUARY 2014

SACRAMENTO COUNTY
MUNICIPAL SERVICES AGENCY

**CAST IRON 24" MANHOLE
FRAME & COVER FOR
TYPE G AND 300-1 INLET**

DRAWN BY: S. PIMENTEL
SCALE: NONE
REVISION DATE: 04/07

9-34

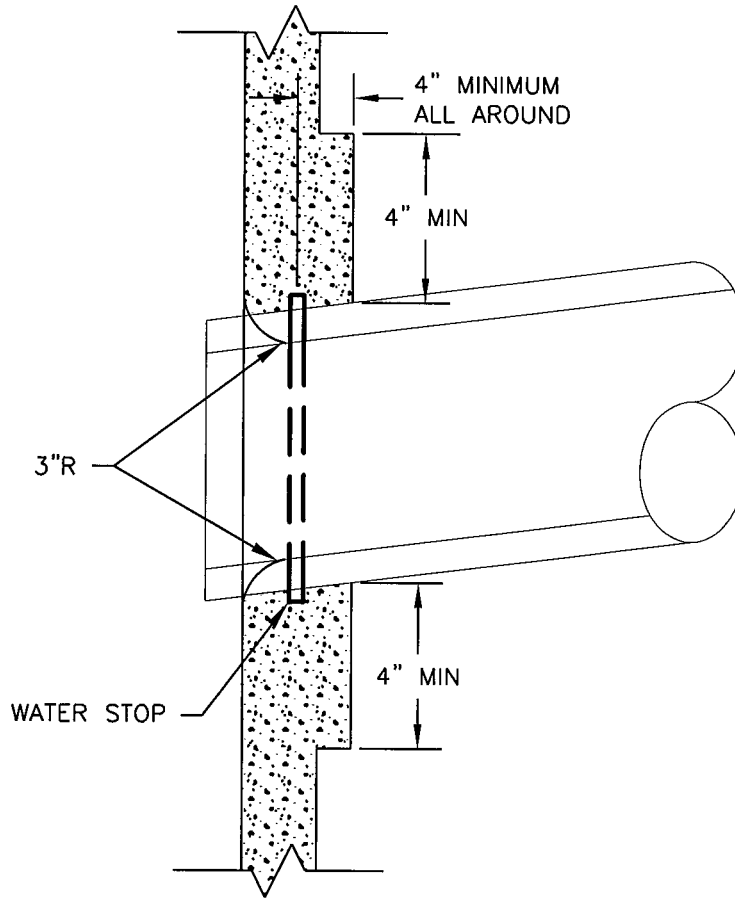

NOTES:

- 1 EMBED PIPE 3" MINIMUM INTO STRUCTURE.
- 2 CENTER WATERSTOP WITHIN STRUCTURE WALL. REMOVE ALL PORTIONS OF PIPE PROTRUDING INTO THE STRUCTURE IN ORDER TO FORM 3" RADIUS BETWEEN PIPE AND STRUCTURE WALL.
- 3 INCREASE WALL THICKNESS OF STRUCTURE BY ADDING A 4" CONCRETE COLLAR AROUND PIPE, AS NEEDED TO ACCOMMODATE MINIMUM EMBEDMENT REQUIREMENTS.
- 4 TO BE USED ON ALL CAST-IN-PLACE STRUCTURES. NOT ALLOWED ON PRE-CAST STRUCTURES.

SACRAMENTO COUNTY
MUNICIPAL SERVICES AGENCY

WATER STOP

DRAWN BY: STAFF
SCALE: NONE
REVISION DATE: 10/09

9-35

Michael L. Peterson

DIRECTOR, DEPARTMENT OF WATER RESOURCES
JANUARY 2014

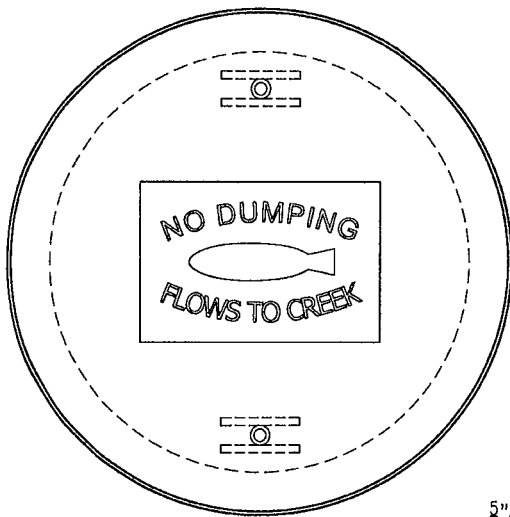

PLAN VIEW

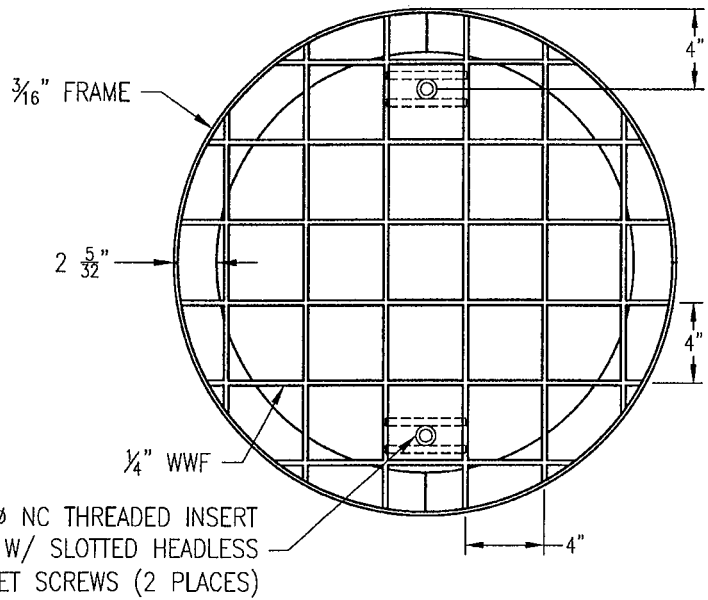

5/8" Ø NC THREADED INSERT
W/ SLOTTED HEADLESS
SET SCREWS (2 PLACES)

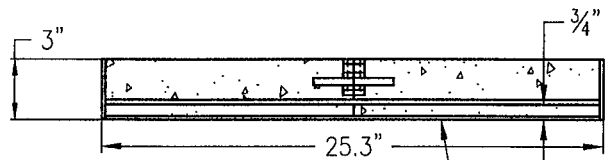

SECTION 3/16" FRAME

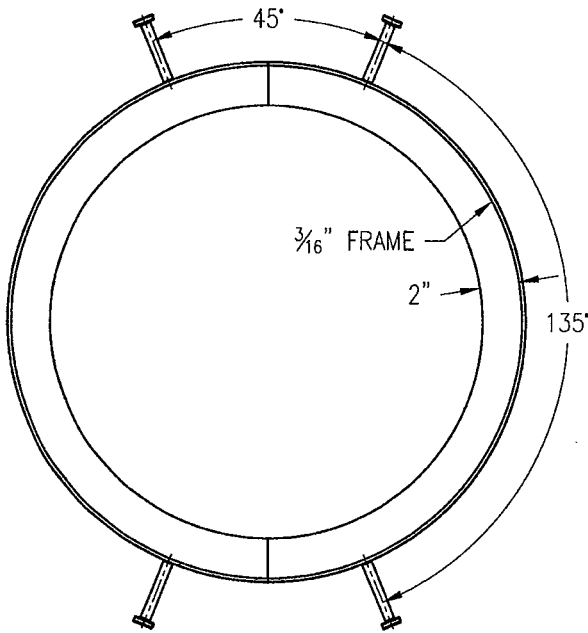

PLAN VIEW

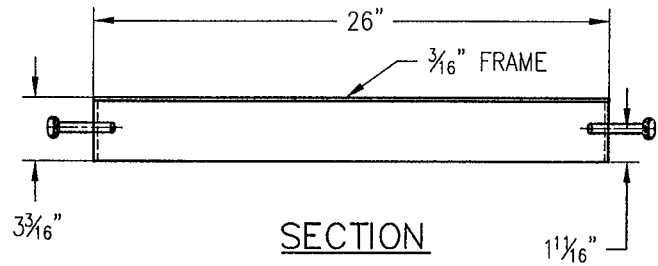

SECTION

Michael Peltz
DIRECTOR, DEPARTMENT OF WATER RESOURCES
NOVEMBER 2015

NOTES:

1. ALL CASTINGS TO CONFORM TO ASTM A48, CLASS 35B.
2. WELDED WIRE FABRIC SHALL CONFORM TO ASTM A185.
3. SHALL ONLY BE USED ON TYPE J INLETS.
4. EXPOSED SURFACES OF THE CASTING WITH THE PARTS ASSEMBLED AND DISASSEMBLED SHALL BE PAINTED WITH COMMERCIAL QUALITY ASPHALTUM PAINT AFTER TESTING AND ASSEMBLY. FRAME CAN BE GALVANIZED STEEL CONFORMING TO ASTM A36 AND A123.
5. WELDED WIRE FABRIC SHALL BE TACK WELD TO FRAME.
6. MANHOLE COVER SHALL HAVE A NON SLIP SURFACE.

SACRAMENTO COUNTY
MUNICIPAL SERVICES AGENCY

**24" MANHOLE FRAME &
COVER FOR TYPE J INLET**

DRAWN BY: STAFF
SCALE: NONE
DATE: 10/15

9-36

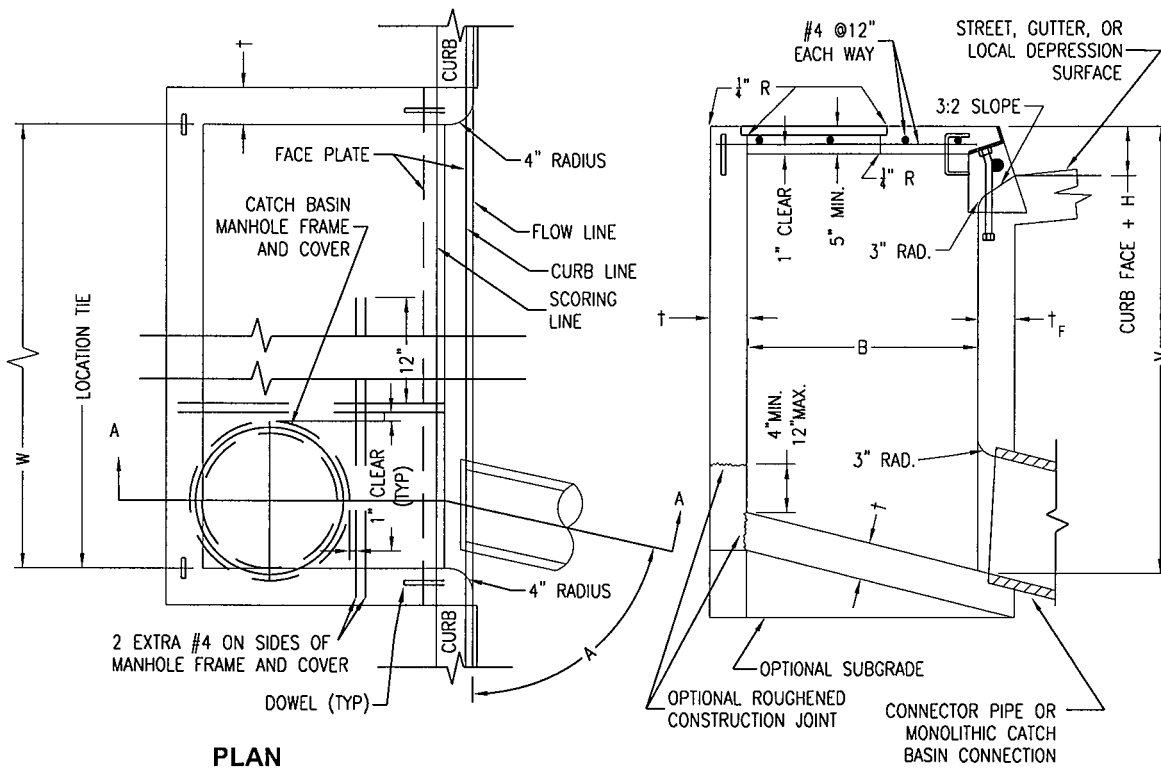

PLAN

SECTION A-A

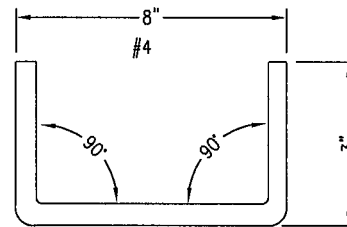

DOWEL DETAIL

STRUCTURAL DATA							
WALL AND SLAB DIMENSIONS AND REINFORCEMENT REQUIREMENTS							
MAX W	MAX V	†	† _F	REINFORCEMENT REQUIRED IN			
				FRONT WALL	REAR WALL	BOTTOM SLAB	END WALL
3.5'	8'	6"	6"	NO REINFORCEMENT REQUIRED			
3.5'	12'	6"	8"				
7'	6'	6"	6"				
7'	12'	8"	8"				
14'	4'	6"	6"				
14'	8'	6"	8"				
14'	12'	8"	10"				
21' AND 28'	4'	6"	6"				
	6'	6"	8"				
	8'	8"	8"				
	10'	8"	10"				
	12'	8"	10"				

FOR W > 28', V > 12', OR B > 4' SEE PROJECT PLANS

Michael L. Peters

DIRECTOR, DEPARTMENT OF WATER RESOURCES
JANUARY 2014

SACRAMENTO COUNTY
MUNICIPAL SERVICES AGENCY

**CURB OPENING
CATCH BASIN**

DRAWN BY: L.PETERS
SCALE: NONE
REVISION DATE: 12/02

300-1
SHEET 1 OF 2

NOTES:

1. WHERE THE BASIN IS TO BE CONSTRUCTED WITHIN THE LIMITS OF EXISTING OR PROPOSED SIDEWALK OR IS CONTIGUOUS TO SUCH SIDEWALK, THE TOP SLAB OF THE BASIN MAY BE POURED EITHER MONOLITHIC WITH THE SIDEWALK OR SEPARATELY, USING THE SAME CLASS OF CONCRETE AS IN THE BASIN. WHEN POURED MONOLITHICALLY, THE SIDEWALK SHALL BE PROVIDED WITH A WEAKENED PLANE OR A 1-INCH DEEP SAWCUT CONTINUOUSLY AROUND THE EXTERNAL PERIMETER OF THE CATCH BASIN WALLS, INCLUDING ACROSS THE FULL WIDTH OF THE SIDEWALK. SURFACE OF ALL EXPOSED CONCRETE SHALL CONFORM IN SLOPE, GRADE, COLOR, FINISH, AND SCORING TO EXISTING OR PROPOSED CURB AND WALK ADJACENT TO THE BASIN.
2. ALL CURVED CONCRETE SURFACES SHALL BE FORMED BY CURVED FORMS, AND SHALL NOT BE SHAPED BY PLASTERING.
3. FLOOR OF BASIN SHALL BE GIVEN A STEEL TROWEL FINISH AND SHALL HAVE A LONGITUDINAL AND LATERAL SLOPE OF 1:12 MINIMUM AND 1:3 MAXIMUM, EXCEPT WHERE THE GUTTER GRADE EXCEEDS 8 PERCENT, IN WHICH CASE THE LONGITUDINAL SLOPE OF THE FLOOR SHALL BE THE SAME AS THE GUTTER GRADE. SLOPE FLOOR FROM ALL DIRECTIONS TO THE OUTLET.
4. DIMENSIONS:
 - B = 3 FEET 2 INCHES
 - V = THE DIFFERENCE IN ELEVATION BETWEEN THE TOP OF THE CURB AND THE INVERT OF THE CATCH BASIN AT THE OUTLET. NOTED ON THE PROJECT PLANS.
 - V_u = THE DIFFERENCE IN ELEVATION BETWEEN THE TOP OF THE CURB AND THE INVERT AT THE UPSTREAM END OF THE BASIN, AND SHALL BE DETERMINED BY THE REQUIREMENTS OF NOTE 3, BUT SHALL NOT BE LESS THAN CURB FACE PLUS 12 INCHES.
 - V_i = THE DIFFERENCE IN ELEVATION BETWEEN THE TOP OF THE CURB AND THE INVERT OF THE INLET. NOTED ON THE PROJECT PLANS.
 - H = NOTED ON THE PROJECT PLANS.
 - W = NOTED ON THE PROJECT PLANS.
 - A = THE ANGLE, IN DEGREES, INTERCEPTED BY THE CENTERLINE OF THE CONNECTOR PIPE AND THE CATCH BASIN WALL TO WHICH THE CONNECTOR PIPE IS ATTACHED.
5. PLACE CONNECTOR PIPE AS INDICATED ON THE PROJECT PLANS UNLESS OTHERWISE SPECIFIED. THE CONNECTOR PIPE SHALL BE LOCATED AT THE DOWNSTREAM END OF THE BASIN. WHERE THE CONNECTOR PIPE IS SHOWN AT A CORNER, THE CENTERLINE OF THE PIPE SHALL INTERSECT THE INSIDE CORNER OF THE BASIN. THE PIPE MAY BE CUT AND TRIMMED AT A SKEW NECESSARY TO INSURE MINIMUM 3-INCH PIPE EMBEDMENT ALL AROUND, WITHIN THE CATCH BASIN WALL, AND 3-INCH RADIUS OF ROUNDING OF STRUCTURE CONCRETE, ALL AROUND, ADJACENT TO PIPE ENDS. A MONOLITHIC CATCH BASIN CONNECTION SHALL BE USED TO JOIN THE CONNECTOR PIPE TO THE CATCH BASIN WHENEVER ANGLE "A" IS LESS THAN 70 DEGREES OR GREATER THAN 110 DEGREES, OR WHENEVER THE CONNECTOR PIPE IS LOCATED IN A CORNER. THE OPTIONAL USE OF A MONOLITHIC CATCH BASIN CONNECTION IN ANY CASE IS PERMITTED. MONOLITHIC CATCH BASIN CONNECTIONS MAY BE CONSTRUCTED TO AVOID CUTTING STANDARD LENGTHS OF PIPE.
6. DOWELS ARE REQUIRED AT EACH CORNER AND AT 7 FEET ON CENTER (MAXIMUM) ALONG THE BACKWALL.
7. THE FOLLOWING STANDARD PLANS ARE INCORPORATED HEREIN:
 - 308 MONOLITHIC CATCH BASIN CONNECTION
 - 309 CATCH BASIN REINFORCEMENT
 - 9-17 CATCH BASIN FACE PLATE ASSEMBLY AND PROTECTION BAR
 - 9-34 CATCH BASIN MANHOLE FRAME AND COVER



DIRECTOR, DEPARTMENT OF WATER RESOURCES
JANUARY 2014

SACRAMENTO COUNTY
MUNICIPAL SERVICES AGENCY

**CURB OPENING
CATCH BASIN**

DRAWN BY: L.PETERS
SCALE: NONE
REVISION DATE: 10/09

300-1
SHEET 2 OF 2

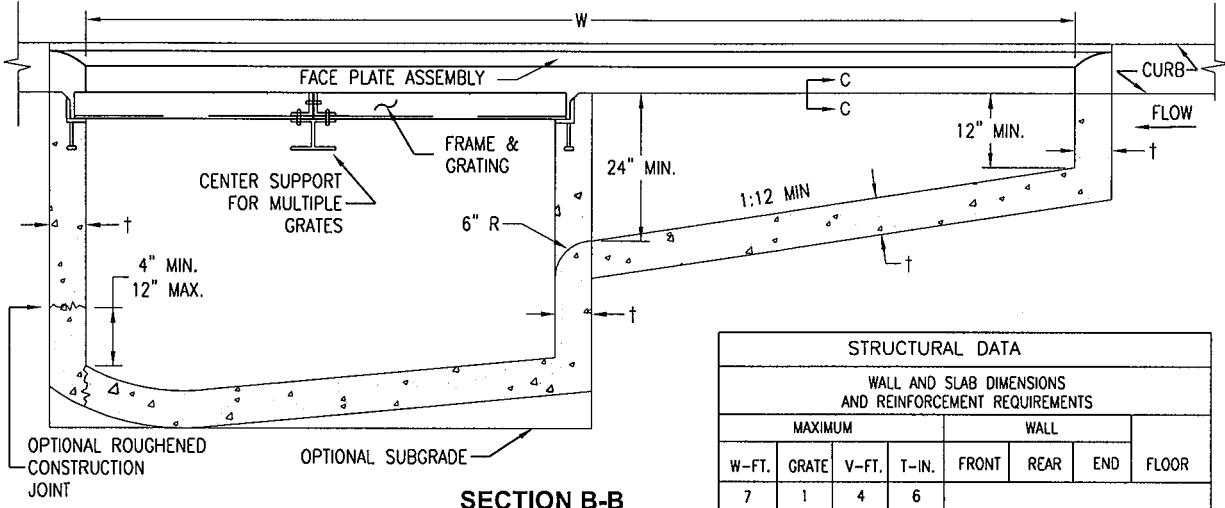
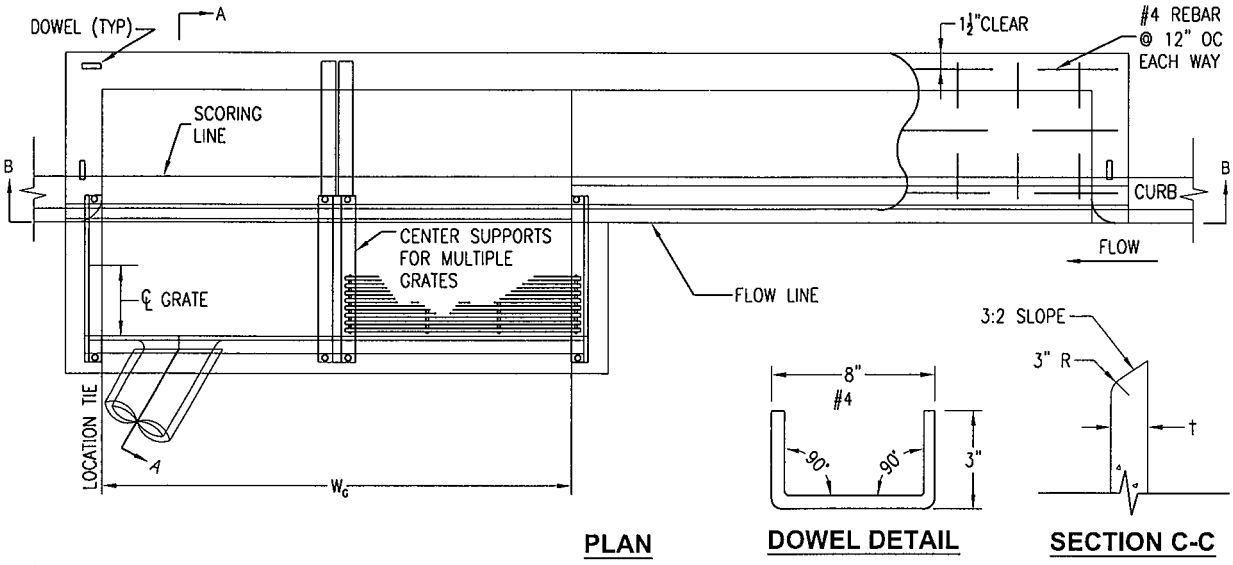

STRUCTURAL DATA							
WALL AND SLAB DIMENSIONS AND REINFORCEMENT REQUIREMENTS							
W-FT.	GRATE	V-FT.	T-IN.	WALL			FLOOR
				FRONT	REAR	END	
7	1	4	6	NO REINFORCEMENT REQUIRED			
7	1	8	8				
7	1	10	10				
14	3	4	6				
14	2	8	8				
14	2	10	10				
14	2	12	10				
28	6	4	6	REINFORCEMENT REQUIRED			
28	6	6	8				
28	7	4	6				
28	7	8	8				
28	7	10	10				
28	7	12	10				

FOR W > 28', V > 12', OR NO. OF GRATES > 7, SEE PROJECT PLANS

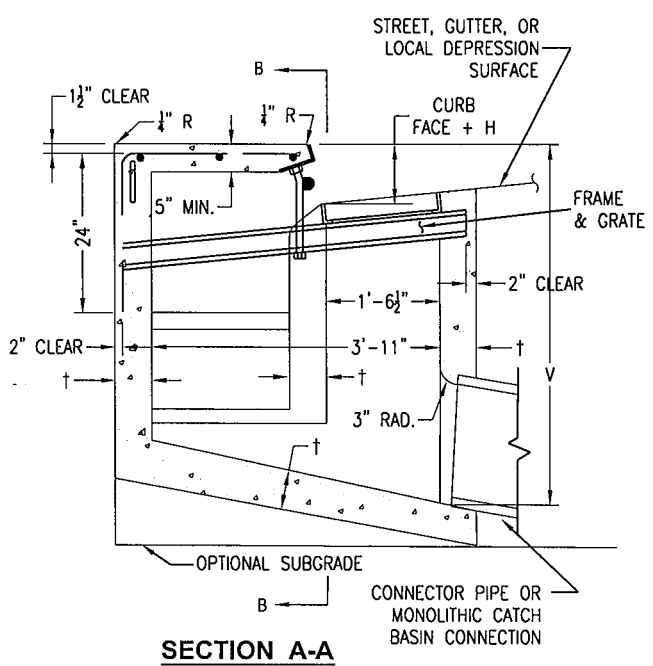

Michael L. Peters
 DIRECTOR, DEPARTMENT OF WATER RESOURCES
 JANUARY 2014

**SACRAMENTO COUNTY
 MUNICIPAL SERVICES AGENCY**

**CURB OPENING
 CATCH BASIN**

DRAWN BY: L.PETERS
 SCALE: NONE
 REVISION DATE: 12/02

301-1
 SHEET 1 OF 2

NOTES:

1. WHERE THE BASIN IS TO BE CONSTRUCTED WITHIN THE LIMITS OF EXISTING OR PROPOSED SIDEWALK OR IS CONTIGUOUS TO SUCH SIDEWALK, THE TOP SLAB OF THE BASIN MAY BE POURED EITHER MONOLITHIC WITH THE SIDEWALK OR SEPARATELY, USING THE SAME CLASS OF CONCRETE AS IN THE BASIN. WHEN POURED MONOLITHICALLY, THE SIDEWALK SHALL BE PROVIDED WITH A WEAKENED PLANE OR A 1-INCH DEEP SAWCUT CONTINUOUSLY AROUND THE EXTERNAL PERIMETER OF THE CATCH BASIN WALLS, INCLUDING ACROSS THE FULL WIDTH OF THE SIDEWALK. SURFACE OF ALL EXPOSED CONCRETE SHALL CONFORM IN SLOPE, GRADE, COLOR, FINISH, AND SCORING TO EXISTING OR PROPOSED CURB AND WALK ADJACENT TO THE BASIN.
2. ALL CURVED CONCRETE SURFACES SHALL BE FORMED BY CURVED FORMS, AND SHALL NOT BE SHAPED BY PLASTERING.
3. FLOOR OF BASIN SHALL BE GIVEN A STEEL TROWEL FINISH. FLOOR OF GRATING PORTION SHALL HAVE A LONGITUDINAL AND LATERAL SLOPE OF 1:12 MINIMUM AND 1:3 MAXIMUM, EXCEPT WHERE THE GUTTER GRADE EXCEEDS 8 PERCENT, IN WHICH CASE THE LONGITUDINAL SLOPE OF THE FLOOR SHALL BE THE SAME AS THE GUTTER GRADE. SLOPE FLOOR FROM ALL DIRECTIONS TO THE OUTLET.
4. DIMENSIONS:
 - V = THE DIFFERENCE IN ELEVATION BETWEEN THE TOP OF THE CURB AND THE INVERT OF THE CATCH BASIN AT THE OUTLET. NOTED ON THE PROJECT PLANS.
 - V_i = THE DIFFERENCE IN ELEVATION BETWEEN THE TOP OF THE CURB AND THE INVERT OF THE INLET. NOTED ON THE PROJECT PLANS.
 - H = NOTED ON THE PROJECT PLANS.
 - W = NOTED ON THE PROJECT PLANS.
 - W_c = 2 FEET 11-3/8 INCHES FOR ONE GRATING; ADD 3 FEET 5-3/8 INCHES FOR EACH ADDITIONAL GRATING. ONE GRATING IS REQUIRED UNLESS OTHERWISE SHOWN ON THE PROJECT PLANS.
 - A = THE ANGLE, IN DEGREES, INTERCEPTED BY THE CENTERLINE OF THE CONNECTOR PIPE AND THE CATCH BASIN WALL TO WHICH THE CONNECTOR PIPE IS ATTACHED.
5. PLACE CONNECTOR PIPE AS INDICATED ON THE PROJECT PLANS UNLESS OTHERWISE SPECIFIED. THE CONNECTOR PIPE SHALL BE LOCATED AT THE DOWNSTREAM END OF THE BASIN. WHERE THE CONNECTOR PIPE IS SHOWN AT A CORNER, THE CENTERLINE OF THE PIPE SHALL INTERSECT THE INSIDE CORNER OF THE BASIN. THE PIPE MAY BE CUT AND TRIMMED AT A SKEW NECESSARY TO INSURE MINIMUM 3-INCH PIPE EMBEDMENT ALL AROUND, WITHIN THE CATCH BASIN WALL, AND 3-INCH RADIUS OF ROUNDING OF STRUCTURE CONCRETE, ALL AROUND, ADJACENT TO PIPE ENDS. A MONOLITHIC CATCH BASIN CONNECTION SHALL BE USED TO JOIN THE CONNECTOR PIPE TO THE CATCH BASIN WHENEVER ANGLE "A" IS LESS THAN 70 DEGREES OR GREATER THAN 110 DEGREES, OR WHENEVER THE CONNECTOR PIPE IS LOCATED IN A CORNER. THE OPTIONAL USE OF A MONOLITHIC CATCH BASIN CONNECTION IN ANY CASE IS PERMITTED. MONOLITHIC CATCH BASIN CONNECTIONS MAY BE CONSTRUCTED TO AVOID CUTTING STANDARD LENGTHS OF PIPE.
6. DOWELS ARE REQUIRED AT EACH CORNER AND AT 7 FEET ON CENTER (MAXIMUM) ALONG THE BACKWALL.
7. THE FOLLOWING STANDARD PLANS ARE INCORPORATED HEREIN:
 - 308 MONOLITHIC CATCH BASIN CONNECTION
 - 309 CATCH BASIN REINFORCEMENT
 - 9-14,15 FRAME AND GRATING FOR CATCH BASINS
 - 9-16 CENTER SUPPORT ASSEMBLY FOR MULTIPLE GRATES
 - 9-17 CATCH BASIN FACE PLATE ASSEMBLY AND PROTECTION BAR
8. THE GRATE SHALL BE PLACED 6" FROM THE BACK OF CURB FOR TYPE 2 CURB AND 8" FROM THE BACK OF CURB FOR TYPE 1 OR 1A CURB.



DIRECTOR, DEPARTMENT OF WATER RESOURCES
JANUARY 2014

SACRAMENTO COUNTY
MUNICIPAL SERVICES AGENCY

**CURB OPENING CATCH BASIN
WITH GRATING(S)
AND DEBRIS SKIMMER**

DRAWN BY: L.PETERS
SCALE: NONE
REVISION DATE: 10/09

301-1
SHEET 2 OF 2

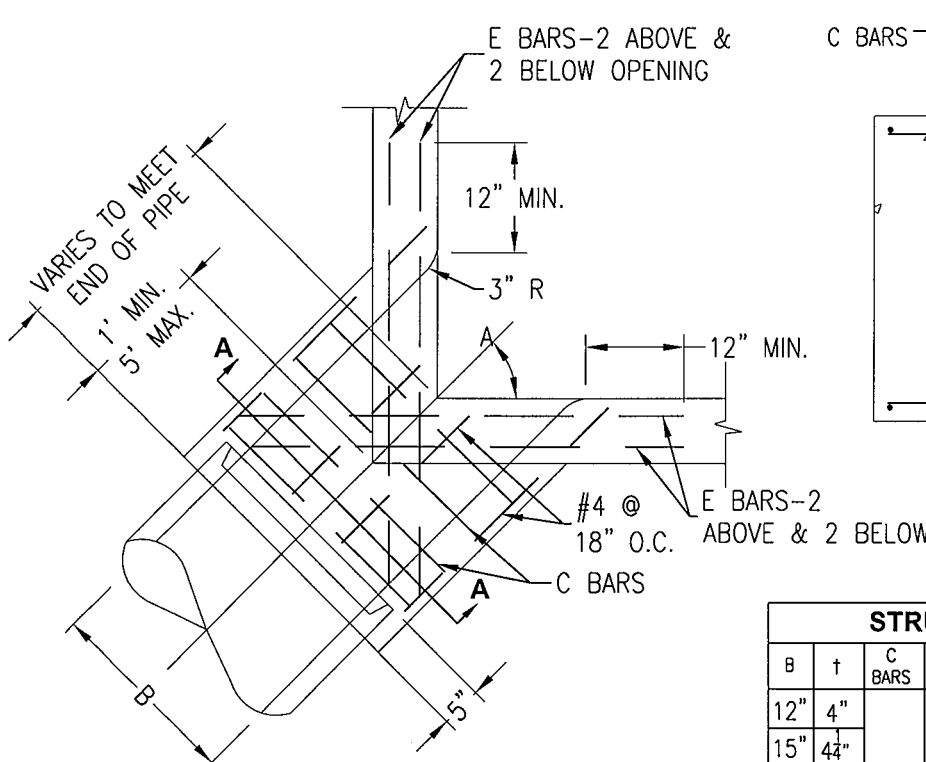

**PLAN
CORNER CONNECTION**

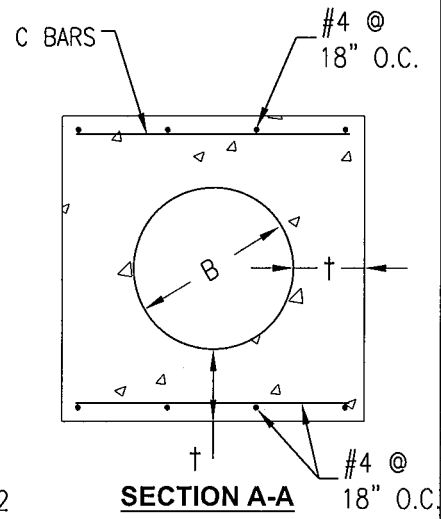

SECTION A-A

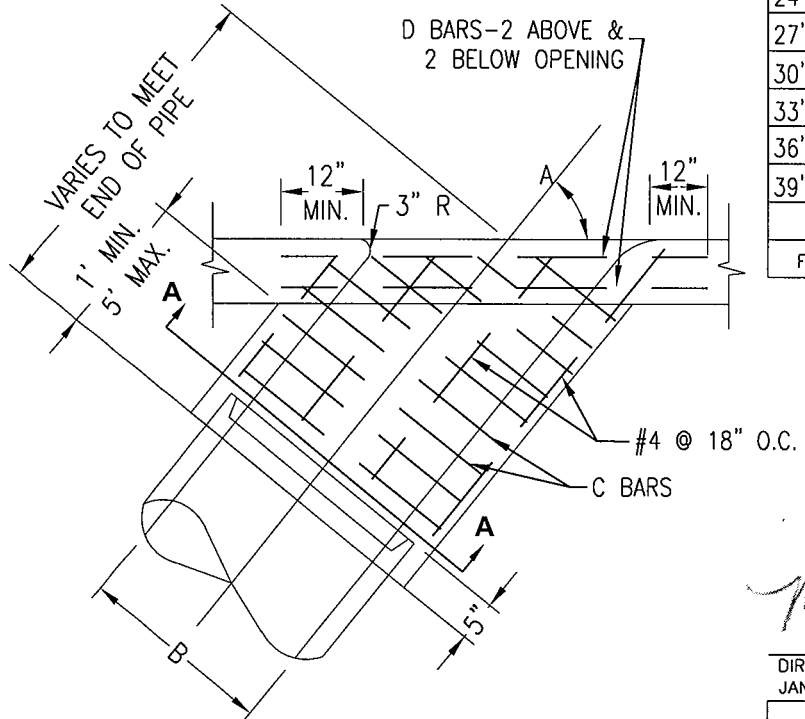

**PLAN
SIDE CONNECTION**

STRUCTURAL DATA							
B	t	C BARS	D&E BARS	B	t	C BARS	D&E BARS
12"	4"	#4 @ 6" O.C.	#5	42"	7 1/2"	#5 @ 6" O.C.	#6
15"	4 1/4"			45"	7 3/4"		
18"	4 1/2"			48"	8"		
21"	5"			51"	8 1/2"		
24"	5 1/4"			54"	9"		
27"	5 1/2"			57"	9 1/4"		
30"	6"			60"	9 3/4"		
33"	6 1/4"			63"	10"		
36"	6 1/2"			66"	10 1/4"		
39"	7"			69"	10 3/4"		
				72"	11"		

FOR B GREATER THAN 72" SEE PROJECT PLAN

Michael L. Peterson

DIRECTOR, DEPARTMENT OF WATER RESOURCES
JANUARY 2014

SACRAMENTO COUNTY
MUNICIPAL SERVICES AGENCY

**MONOLITHIC CATCH
BASIN CONNECTION**

DRAWN BY: D. BOLEN
SCALE: NONE
REVISION DATE: 3/07

308-0
SHEET 1 OF 2

NOTES:

1. REINFORCING STEEL SHALL BE 1-1/2 INCHES CLEAR FROM FACE OF CONCRETE UNLESS OTHERWISE SHOWN.
2. REINFORCING STEEL FOR INSIDE FACE OF CATCH BASIN SHALL BE CUT AT CENTER OF OPENING AND BENT INTO WALLS OF MONOLITHIC CATCH BASIN CONNECTION. REINFORCING STEEL FOR OUTSIDE FACE OF CATCH BASIN SHALL BE CUT 2 INCHES CLEAR OF OPENING.
3. CONNECTION SHALL BE PLACED MONOLITHIC WITH CATCH BASIN. THE ROUNDED EDGE OF OUTLET SHALL BE CONSTRUCTED BY PLACING CONCRETE WITH THE SAME CLASS OF CONCRETE AS THE CATCH BASIN AGAINST A CURVED FORM WITH A RADIUS OF 3 INCHES.
4. CONNECTIONS SHALL BE CONSTRUCTED WHEN:
 - (A) PIPES INLET OR OUTLET THROUGH CORNER OF CATCH BASIN.
 - (B) ANGLE A FOR PIPES THROUGH 30 INCHES IN DIAMETER IS LESS THAN 70 DEGREES OR GREATER THAN 110 DEGREES.



DIRECTOR, DEPARTMENT OF WATER RESOURCES
JANUARY 2014

SACRAMENTO COUNTY
MUNICIPAL SERVICES AGENCY

**MONOLITHIC CATCH
BASIN CONNECTION**

DRAWN BY: L.PETERS
SCALE: NONE
REVISION DATE: 01/02

308-0
SHEET 2 OF 2

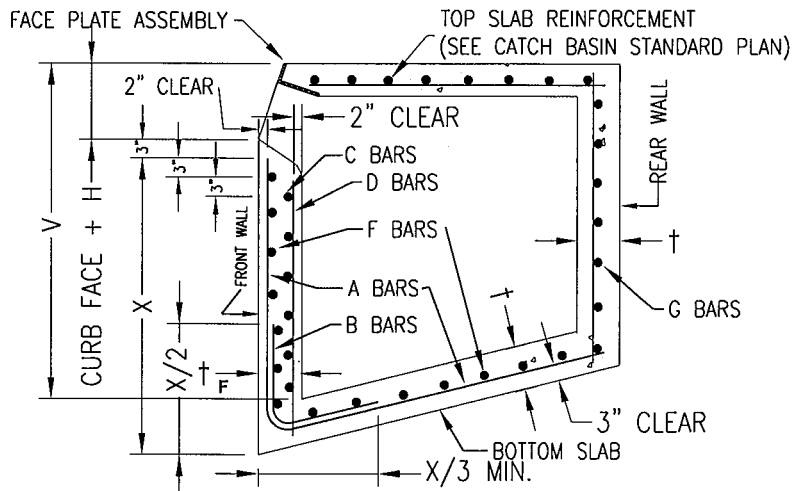

TYPICAL REINFORCEMENT DETAILS

MAX. W	MAX. V	†	† _F	A&B BARS	C BARS	D BARS	E BARS	F BARS	G BARS
3.5'	8'	6"	-	-	-	-	-	-	-
3.5'	12'	8"	8"	-	-	-	-	-	-
7'	6'	6"	6"	-	-	-	-	-	-
7'	12'	8"	8"	-	-	-	-	-	-
14'	4'	6"	6"	-	#4@12"	#4@18"	-	-	-
14'	8'	6"	8"	-	#4@12"	#4@18"	-	-	-
14'	12'	8"	10"	-	#4@6"	#4@18"	-	-	-
28'	4'	6"	6"	#4@24"	-	-	-	#4@18"	-
28'	5'	6"	8"	#4@24"	-	-	-	#4@18"	-
28'	6'	6"	8"	#4@18"	-	-	-	#4@18"	-
28'	7'	8"	8"	#4@17"	-	-	-	#4@18"	-
28'	8'	8"	8"	#4@13"	-	-	-	#4@18"	-
28'	9'	8"	10"	#4@15"	-	-	-	#4@18"	-
28'	10'	8"	10"	#4@12"	-	-	-	#4@18"	-
28'	11'	8"	10"	#5@15"	-	-	#4@10"	#4@18"	#4@18"
28'	12'	8"	10"	#6@18"	-	-	#4@9"	#4@18"	#4@18"

FOR W>28', V>12' OR B>4' SEE PROJECT PLANS

CURB OPENING CATCH BASIN REINFORCEMENT

NOTE: UNLESS OTHERWISE SPECIFIED REINFORCEMENT FOR CURB OPENING CATCH BASIN SHALL TERMINATE 2 INCHES FROM FACE OF CONCRETE.

Michael L. Peterson

DIRECTOR, DEPARTMENT OF WATER RESOURCES
JANUARY 2014

SACRAMENTO COUNTY
MUNICIPAL SERVICES AGENCY

**CATCH BASIN
REINFORCEMENT**

DRAWN BY: B.FORRESTER
SCALE: NONE
REVISION DATE: 01/06

309-0
SHEET 1 OF 1